



ACPSIGNS

愛思譜實業

 ACPsigns

Manufacturer of signs system
标识系统制造 | 2018

ACPSIGNS INDUSTRIAL LIMITED



深圳市愛思譜實業有限公司
ACPSIGNS INDUSTRIAL LIMITED
ADD: BLOCK 12, AILIAN INDUSTRIAL ZONE, ZHUGUSHI RD,
WULIAN, LONGGANG DIST, SHENZHEN, CN 518116.
TEL: +86-755-33561908
EMAIL: INFO@ACPSIGNS.COM
WEB: WWW.ACPSIGNS.COM



ACPSIGNS

ACPSIGNS INDUSTRIAL LIMITED
深圳市愛思譜實業有限公司



Manufacturer of signs system

愛思譜實業有限公司

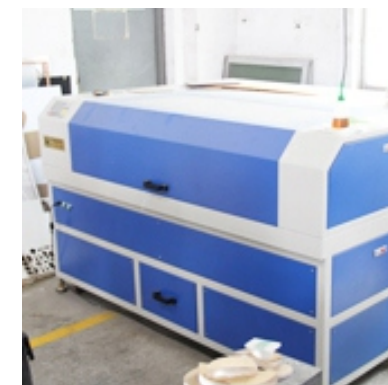

ACPSIGNS INDUSTRIAL LIMITED established in 2003,
now covers 2500 square meter, with more than 60 professional
workers & over 20 large auto high-tech machines.

深圳市愛思譜實業有限公司成立於2003年，發展至今廠房面積
逾2500平方，擁有60多名專業的員工，自動化大型機器20多臺。

SERVICE CASE

服務案例

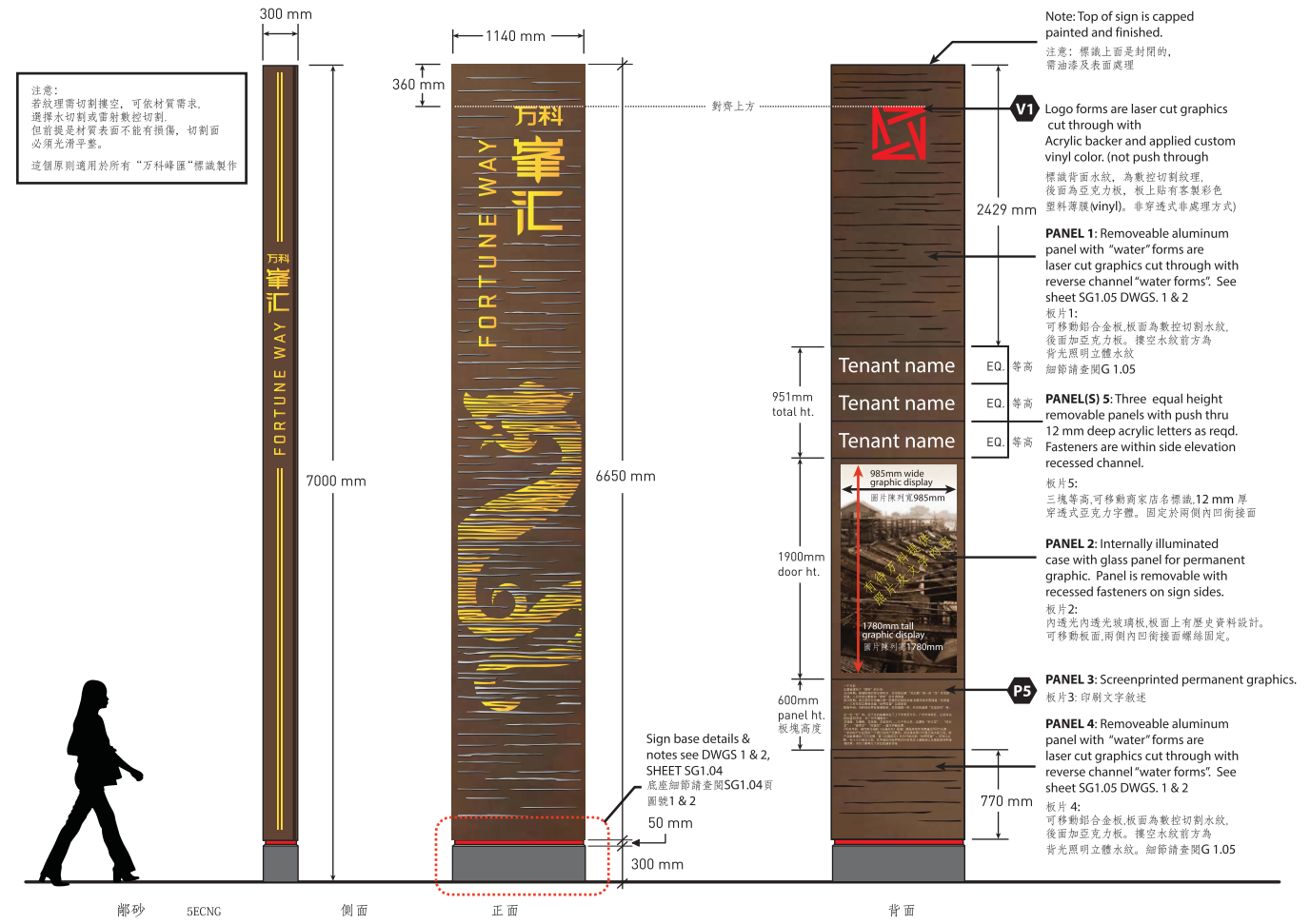

Color Code	Depiction	Description	Manufacturer Paint #	Finish	Material Code	Depiction	Description
P1		COPPER/	Matthews MP20157	Semi Gloss	V1		Transparent Red to match PMS 185c 透明薄膜顏色對照PMS 185c
P2		Gold/	To Match PMS 7406	Semi Gloss	V2		Transparent to match PMS 7501 透明薄膜顏色對照PMS 7501
P3			To Match PMS 7532	Semi Gloss	V3		Frosted Crystal 磨砂水晶塑料薄膜
P4			Matthews MP21942	Semi Gloss	V4		Lumisty塑料薄膜 (這是1種特殊材質, 因角度不同, 紋理會顯現或消失)
P5			To Match PMS 7401	Semi Gloss			Lumisty塑料薄膜
P6		COPPER/	顏色對照室內裝璜MT-01	Semi Gloss			
P7			/1 :3 "	Semi Gloss			

網 TYPEFACES

門網t網

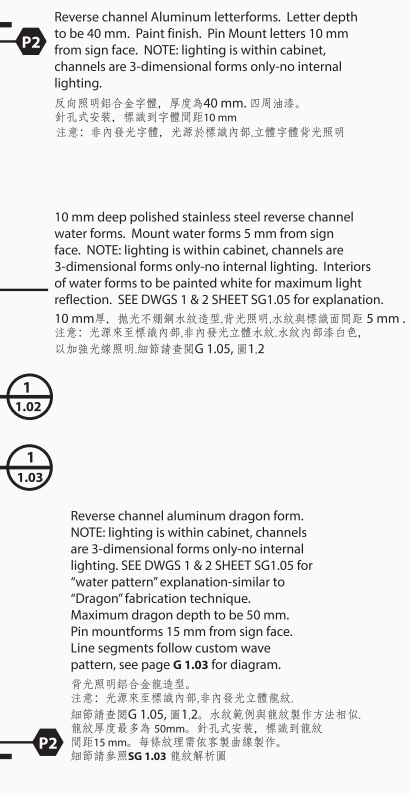
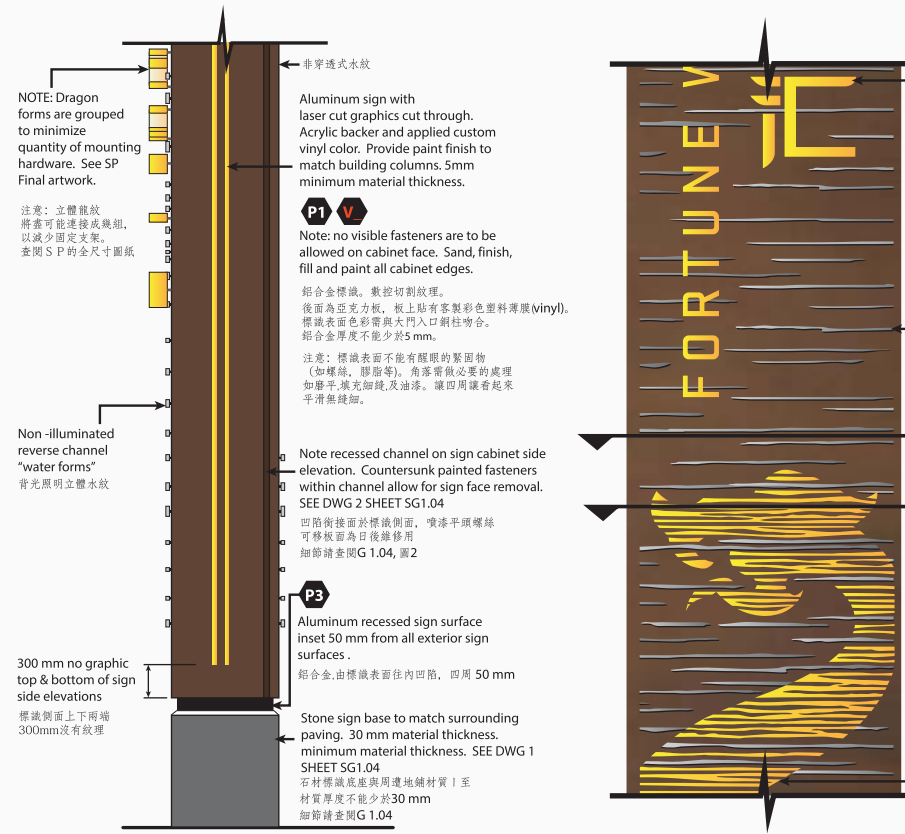

1 側面圖 5KFG 'NGXCVKQP' FGVCKN 5ECNG

2 立面圖(細節) (TQPV 'NGXCVKQP' FGVCKN 5ECNG

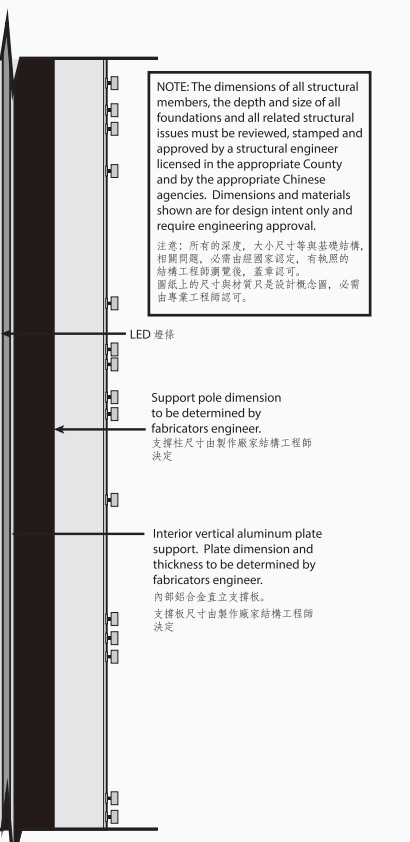
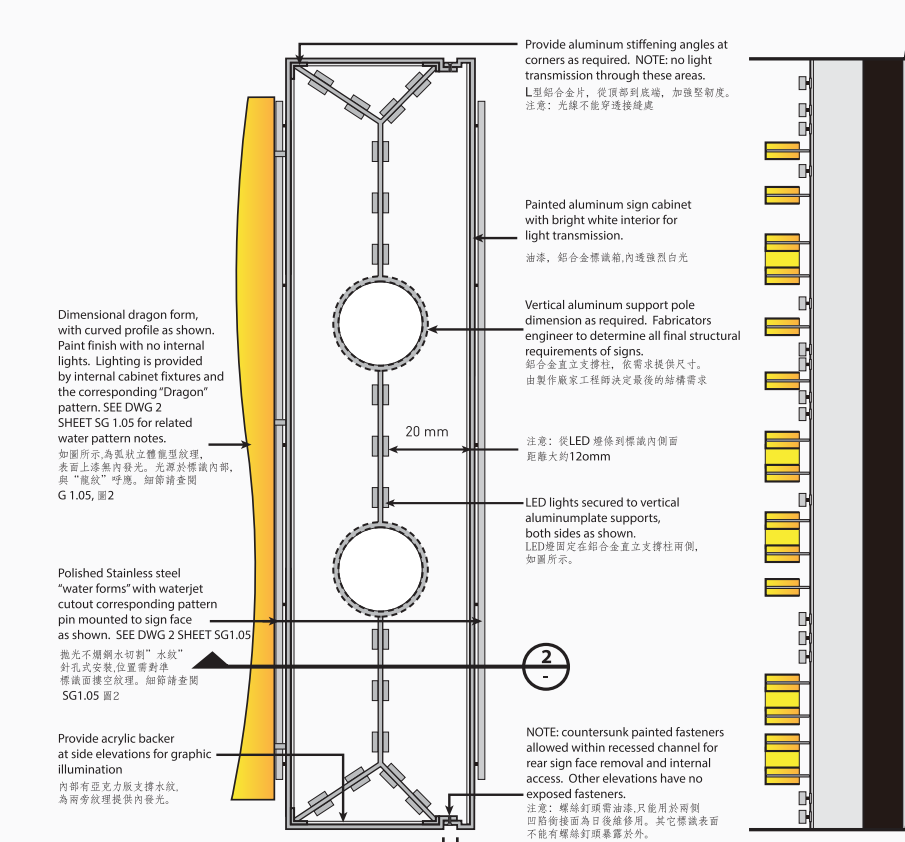

1 平面圖(細節) 2NCP FGVCKN 5ECNG

2 剖面圖(細節) 5GEVKQP FGVCKN 5ECNG

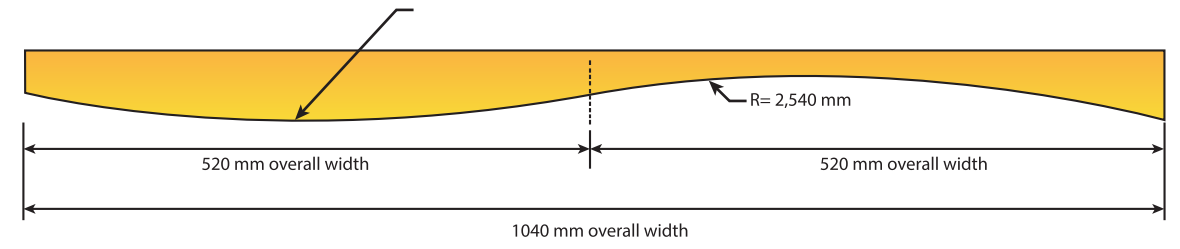

1 平面圖：龍紋解析圖 2NCP & TCIQP EQPVQWT FKICITCO 5ECNG

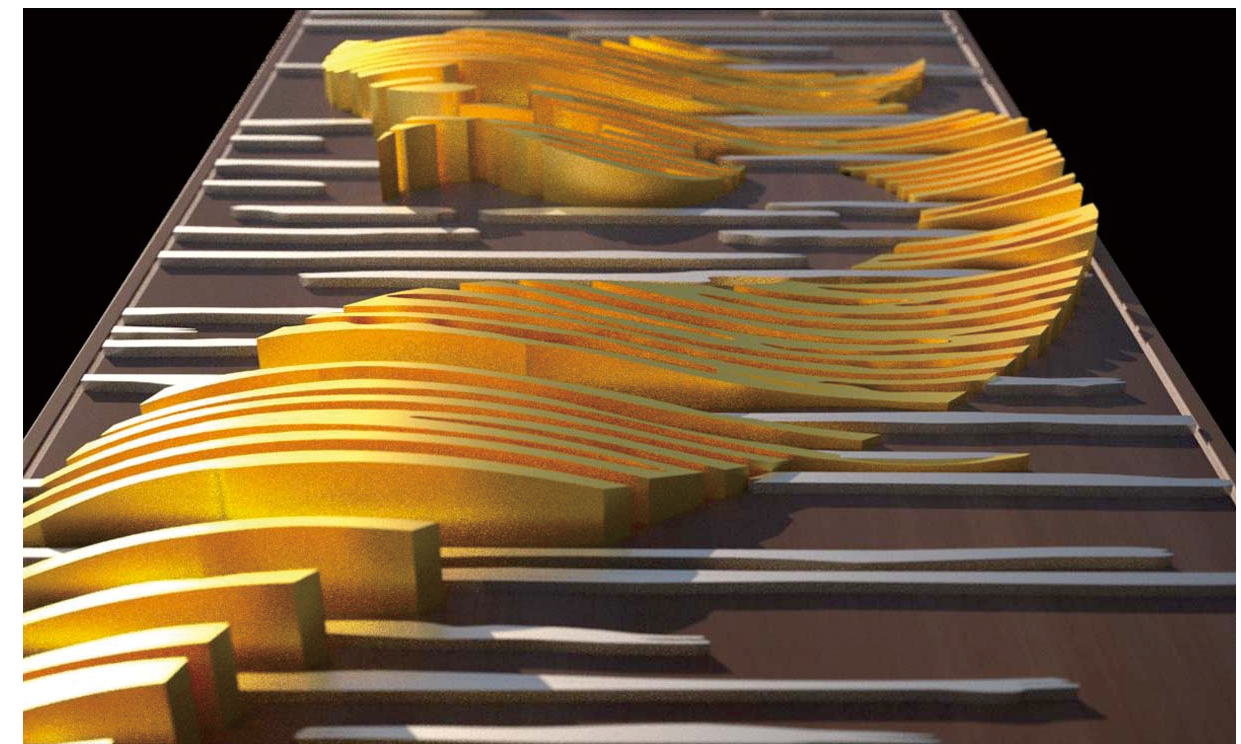

注意：效果圖的色彩及材質並不正確，只能做為立體造型的參考。

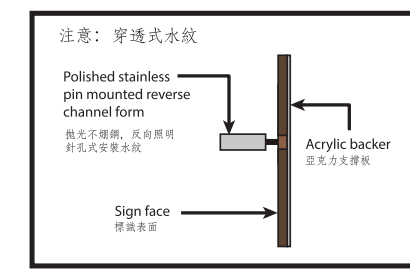

1 5+0 5%G+10 & 6#+. 紋筋形 5ECNG 0 6 5

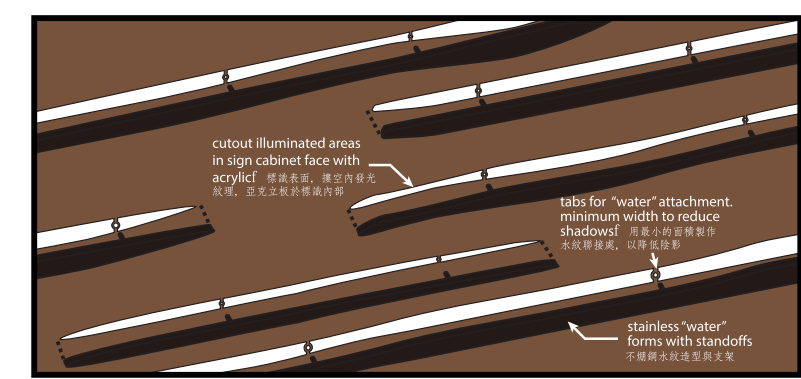

Water pattern detail showing cutout pattern in sign face with illuminated acrylic panel and individual tabs for standoff (spacer) hardware mounting. NOTE: SP ARTWORK will show proposed locations for mounting tabs and waterjet pattern. Waterjet pattern is to be slightly smaller than fabricated stainless water pattern.

水紋細節顯示。標識表面透空水紋。亞克力板於標識內部。內發光。每片水紋片由支撐增加間隔。金屬固定。注意：S P 的全尺寸圖紙會提供標識水紋會提供位置與立體水紋造型位置。標識水紋將比不銹鋼水紋尺寸略微小 1 點。

2 5+0 0 9#6'4 2#66'40r & +#)4#/# 紋o 鮮p 雲 5ECNG 0 6 5

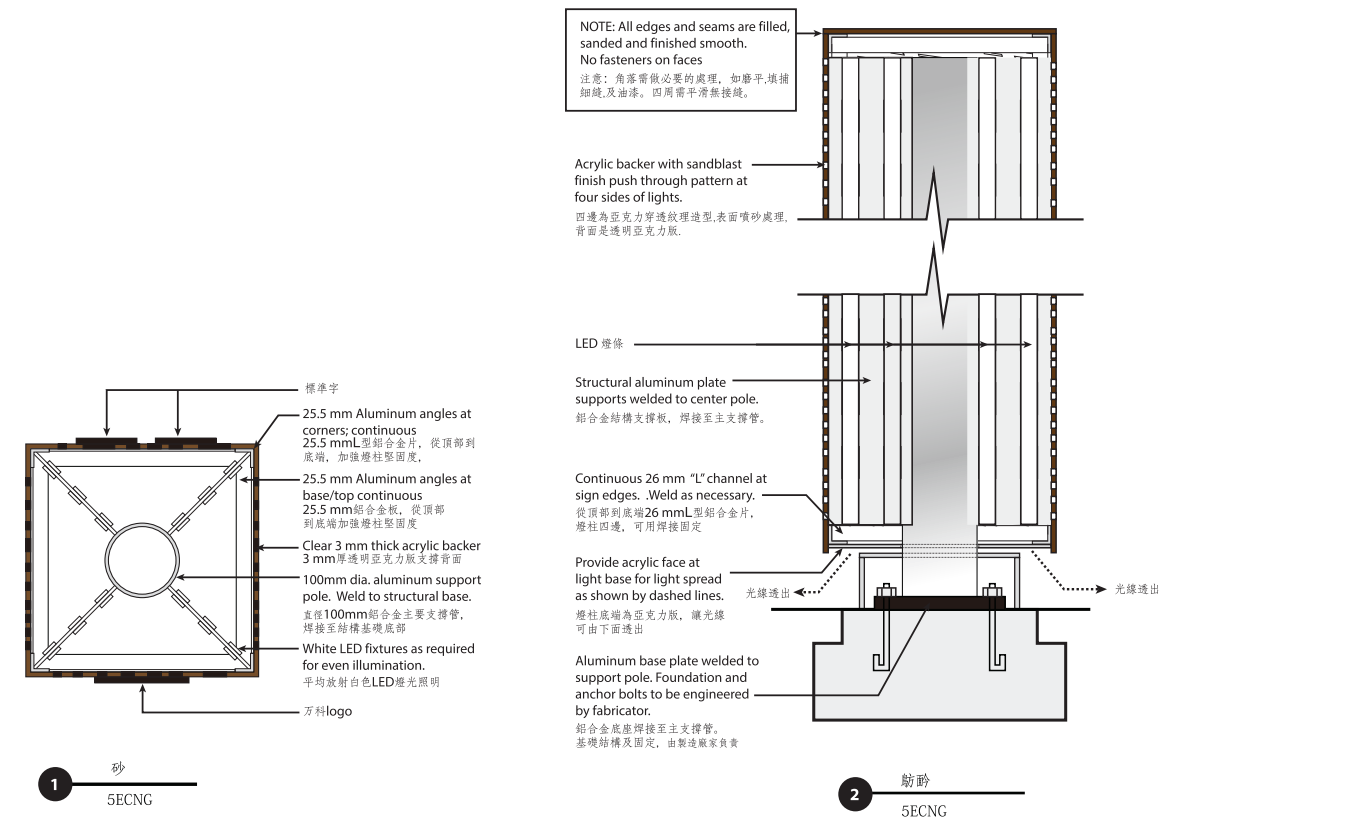
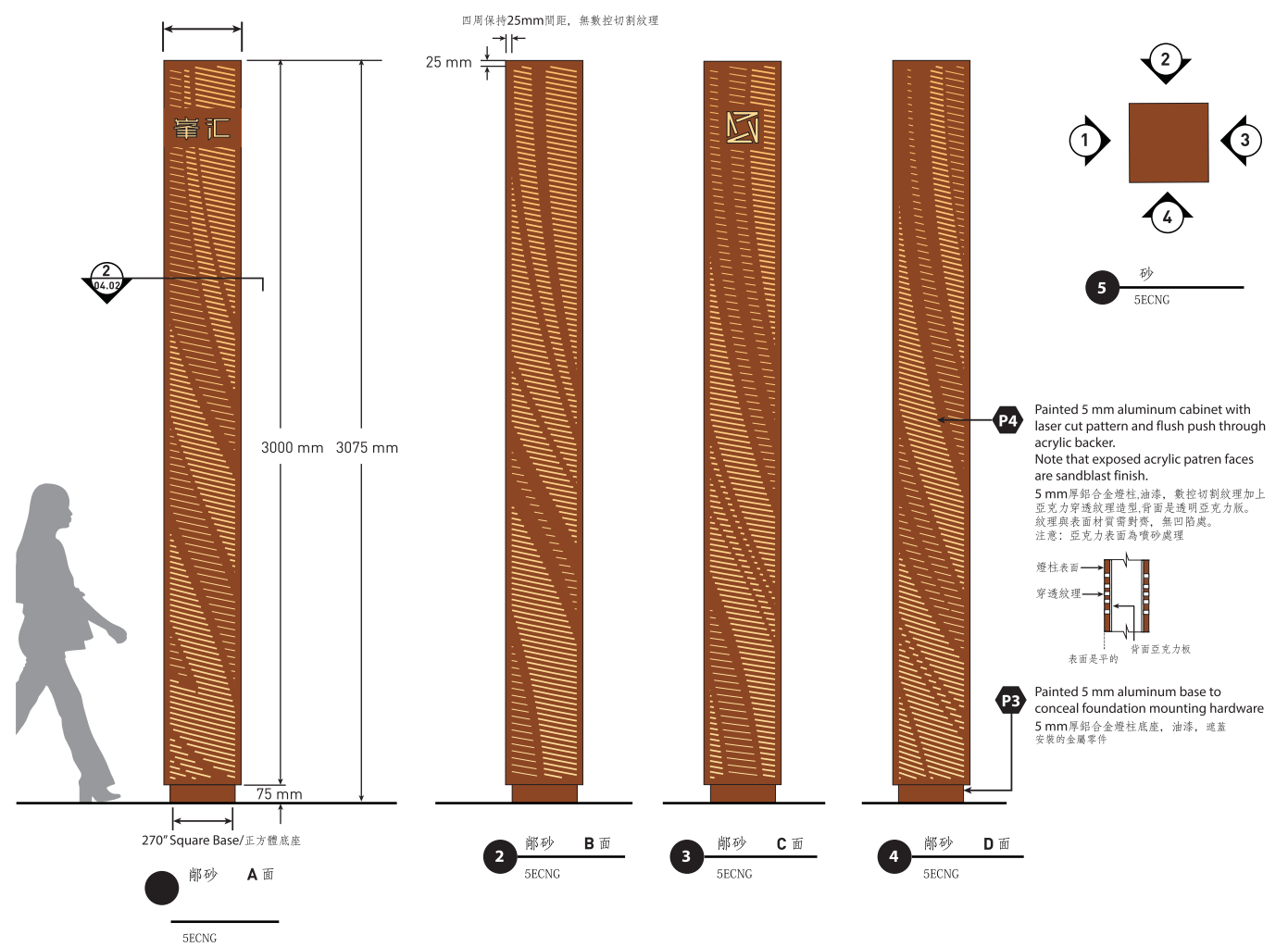
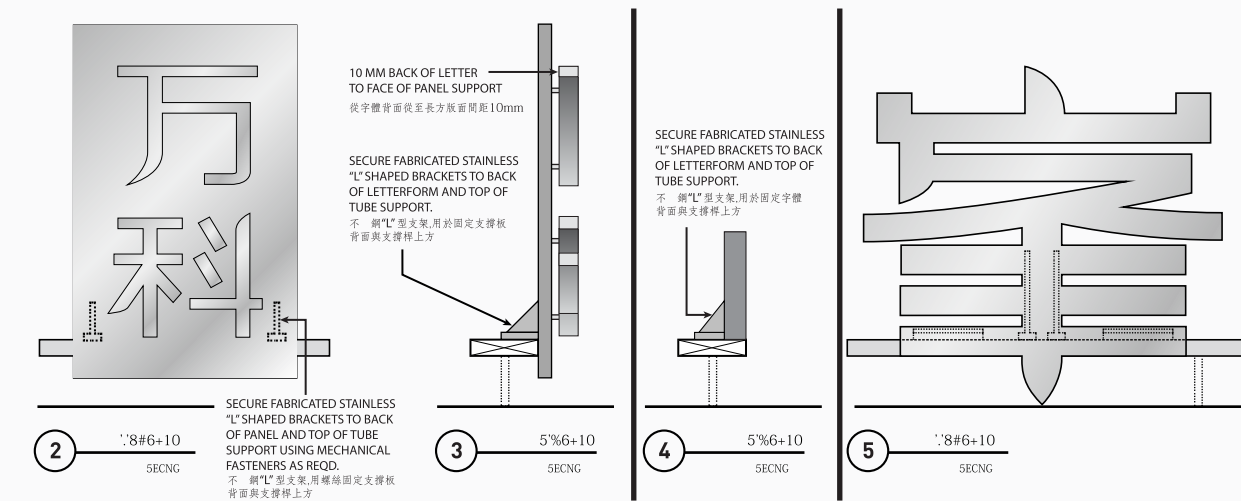
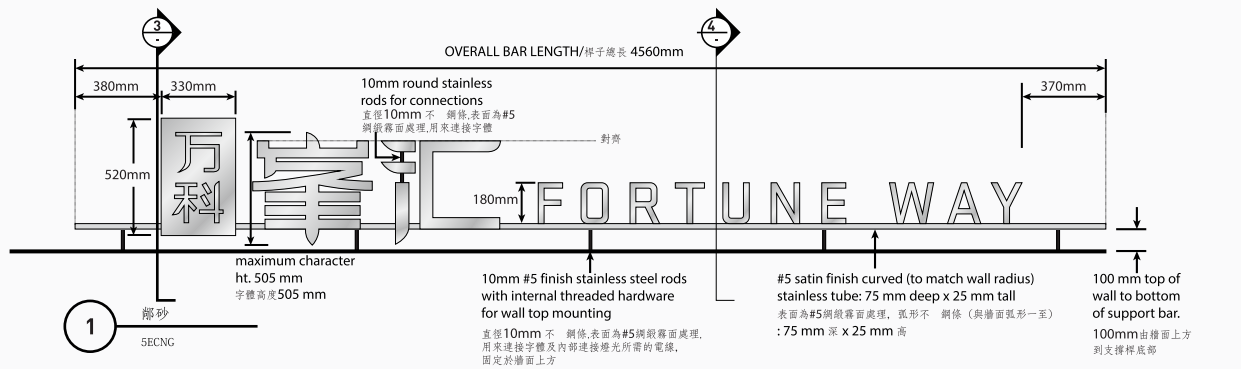
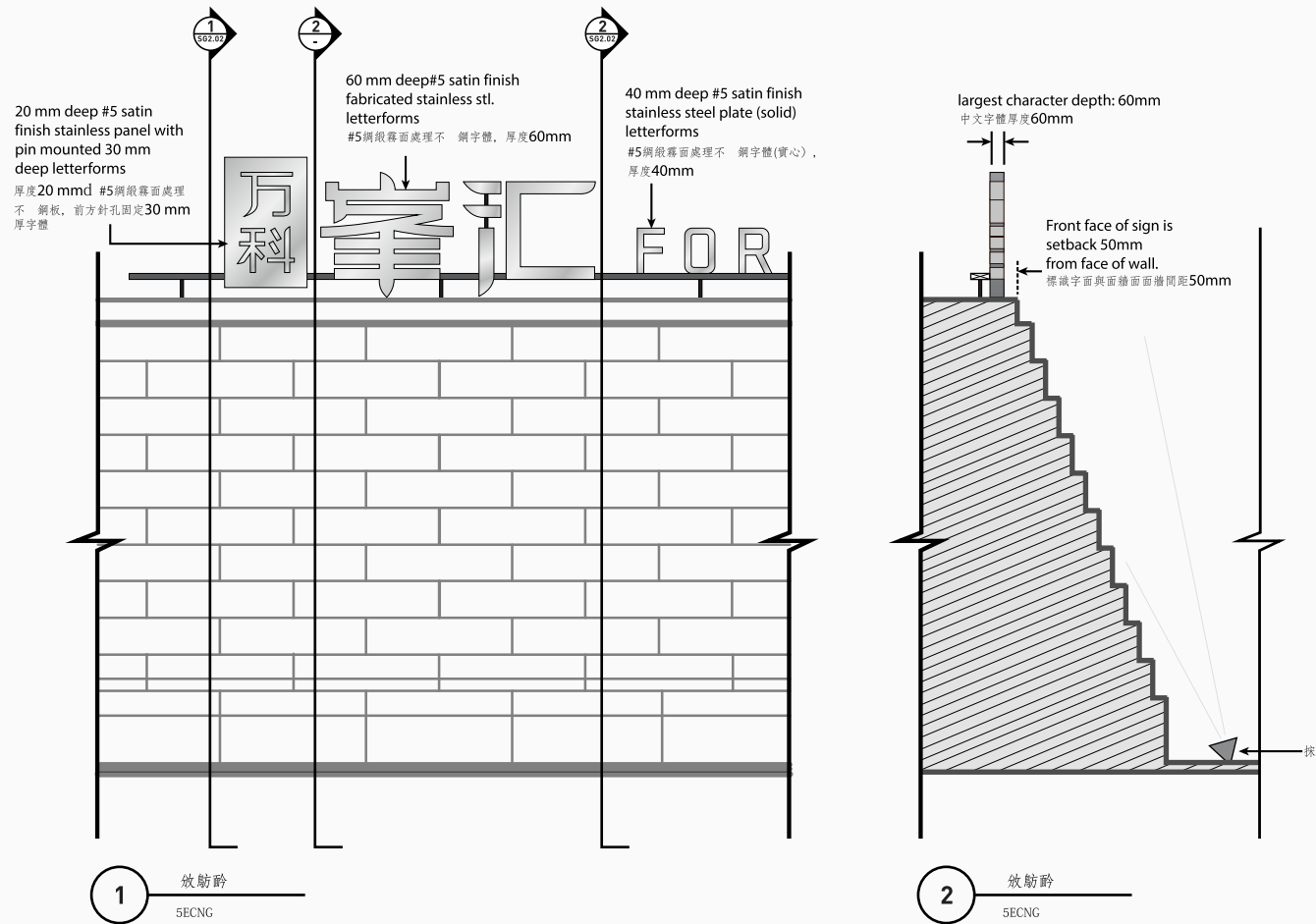

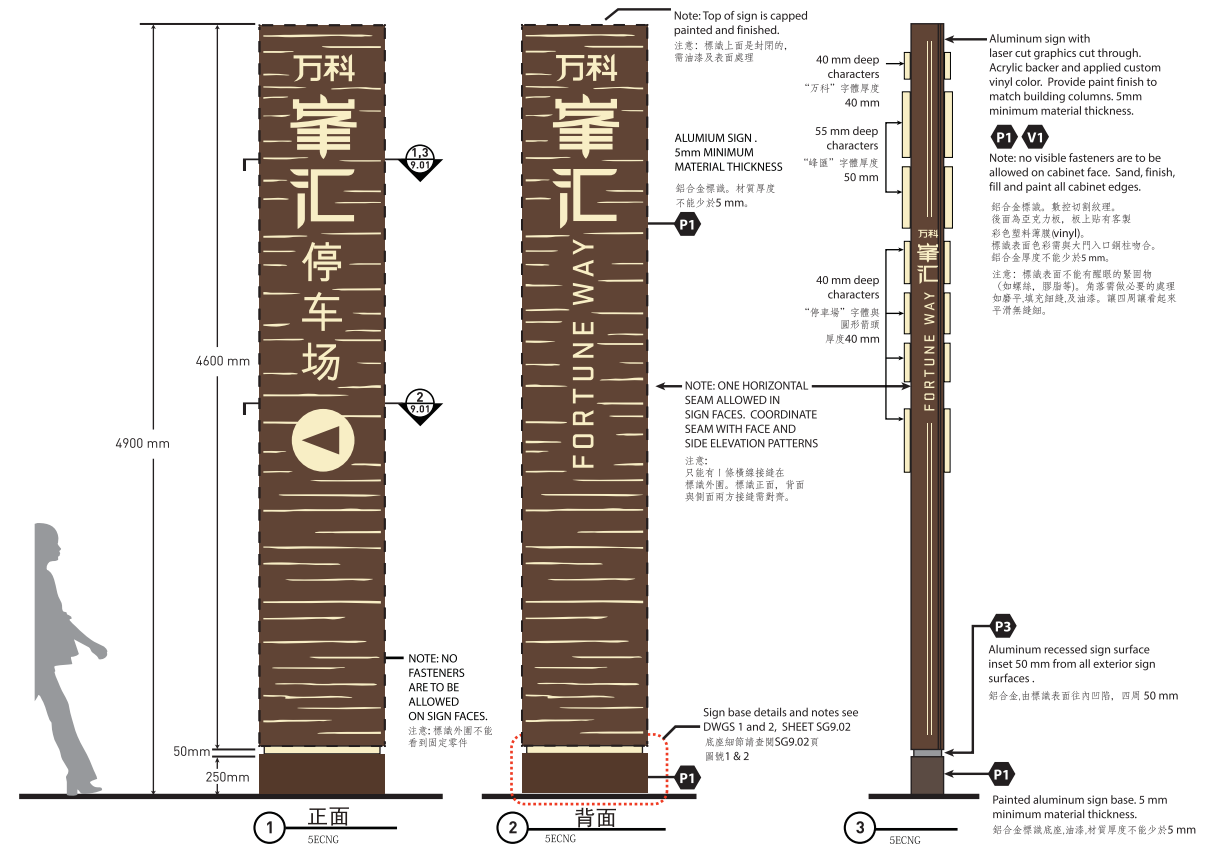
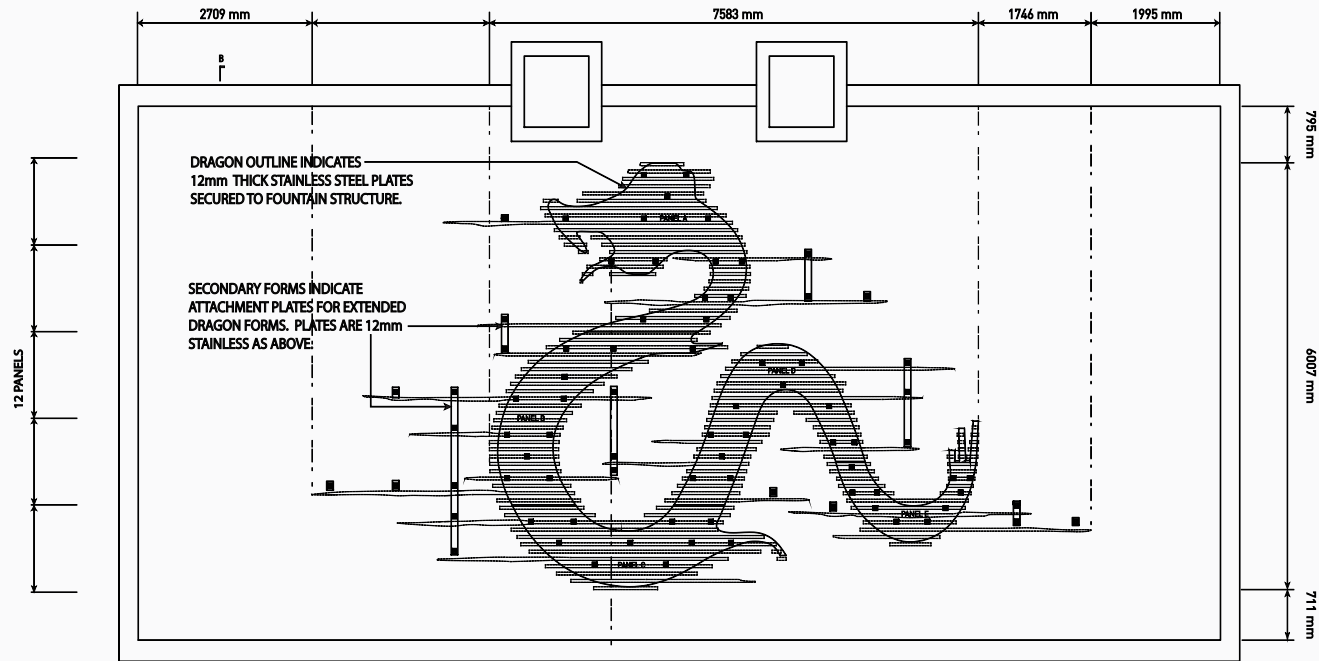



未来城, 项目占地 270 余亩, 总建筑面积 54 万平米, 由 20 幢 28 层以上的高层, 4 幢小高层及 9 栋多层以及 2 幢大型办公酒店和两栋幼儿园组成。本项目采用法式新古典主义建筑风格, 在细节处理方面多运用法式廊柱、雕花线条、制作工艺精细考究, 外墙多采用石材、面砖, 屋顶大量采用斜坡面, 颜色稳重大气呈现一种华贵的气质。

未来城项目的理念是打造一个自然、便捷、低碳的高科技生活社区, 从选址、规划、设计到建造、运营, 的各个阶段努力实现全生命周期内的低碳、高效。集合了酒店, 购物, 休闲, 文化, 办公, 居住等一系列的活动, 使得用户可以在步行的距离内完成日常生活需求。

Future City, the project covers an area of 270 mu, with a total construction area of 540,000 square meters, more than 20 buildings and each building owns 28 floors, 4 small high-rise and 9 multi-storey buildings, two large office hotel and 2 kindergartens This project uses the French neo-classical architectural style, the details of the deal more use of French pillars, carved lines, fine craftsmanship elegant process. exterior walls use more stone, brick, roof slope with unique color, so they display a luxurious temperament.

Future City project idea is to create a natural, convenient, low-carbon community life. So from site selection, planning and design to construction, operation, it strives to achieve the whole life cycle of low-carbon and efficient. Future City owns the hotel, shopping, leisure, culture, office, residential, etc., so that the user can complete the daily needs within walking distance.

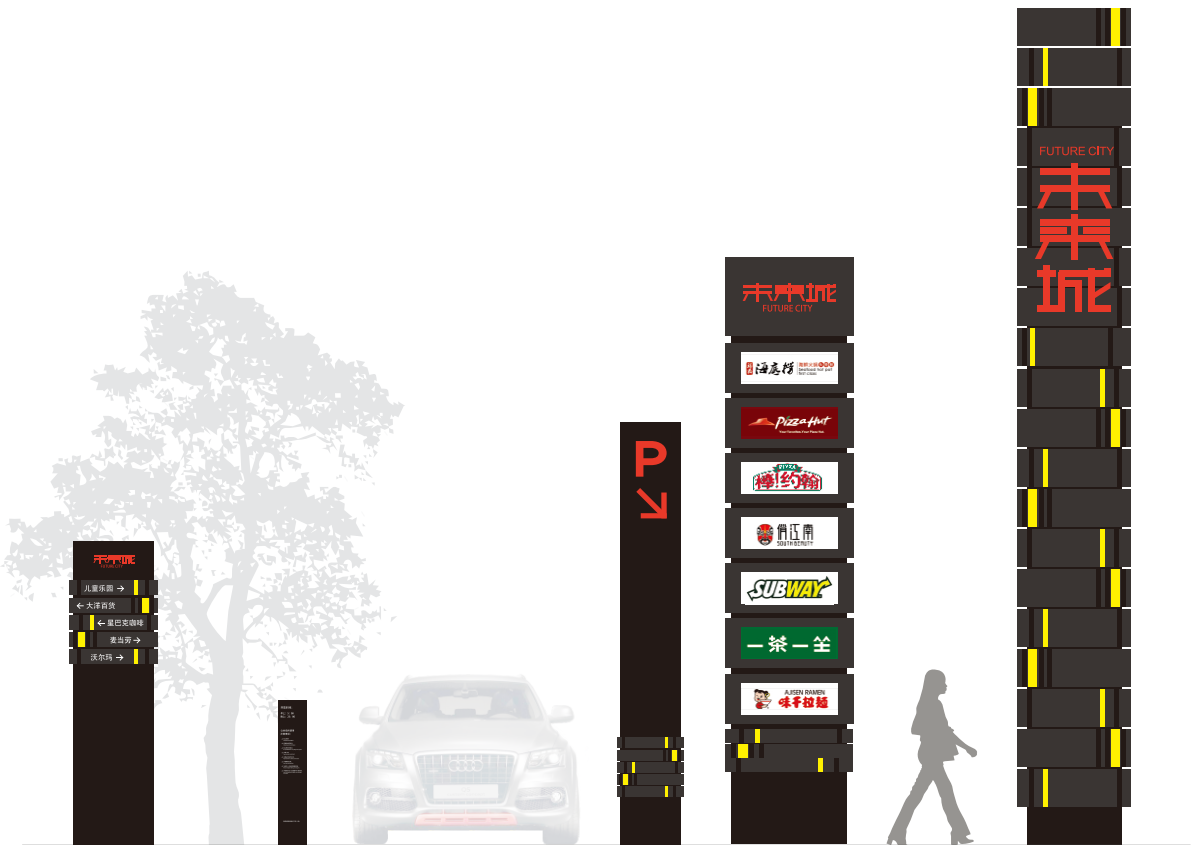

Typefaces

ABCDEFGHIJKLMNOPQRSTUVWXYZ
abcdefghijklmnopqrstuvwxyz
1234567890!?!&

Icons



Flecha

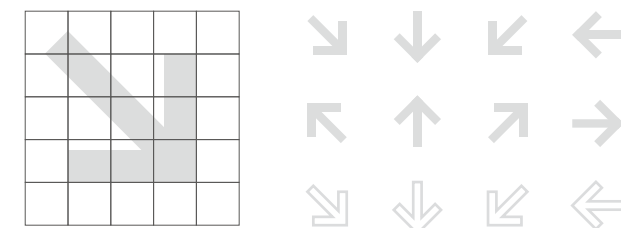

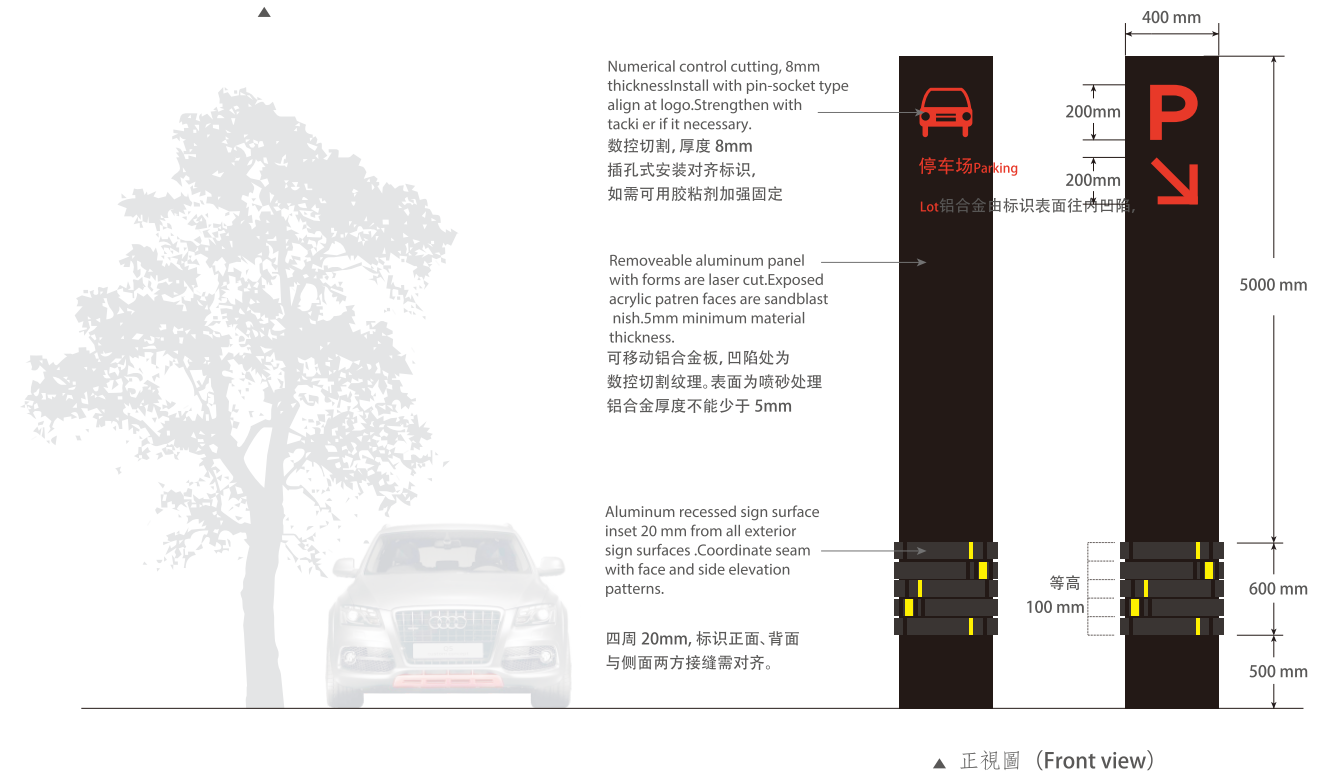
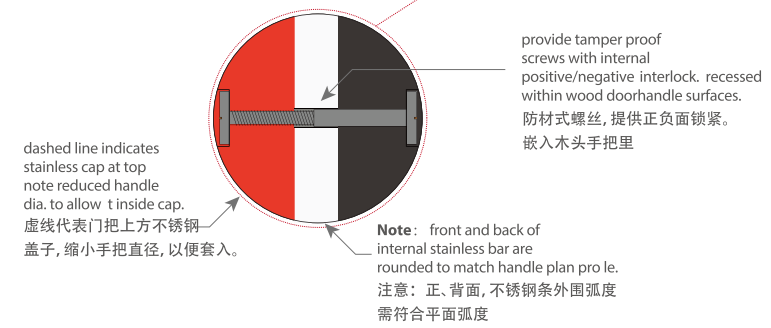
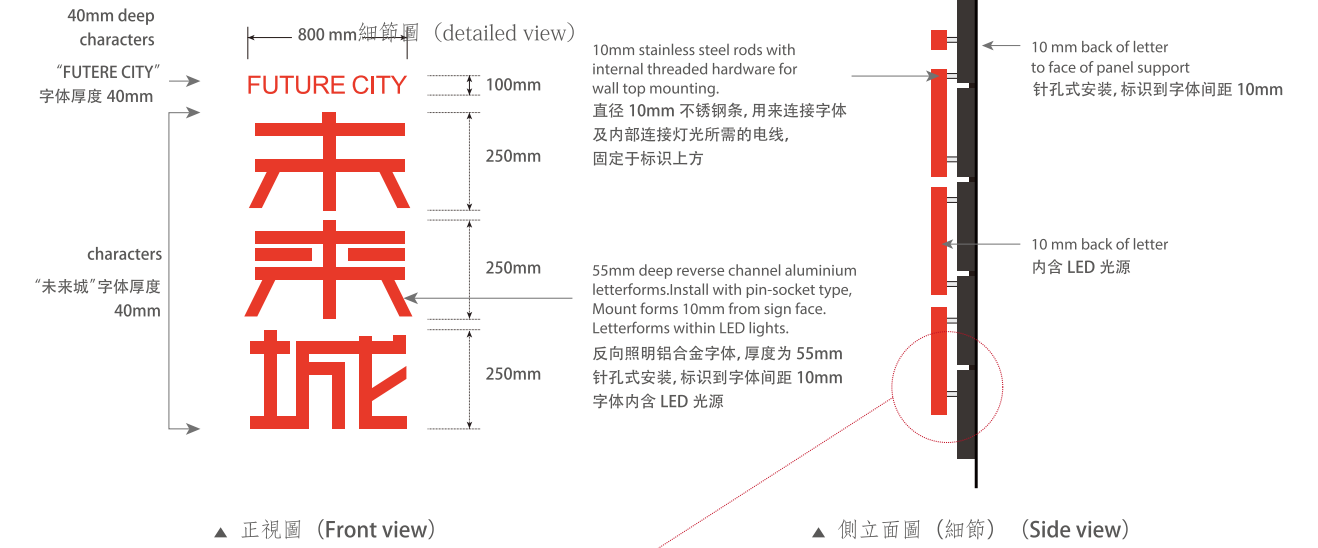
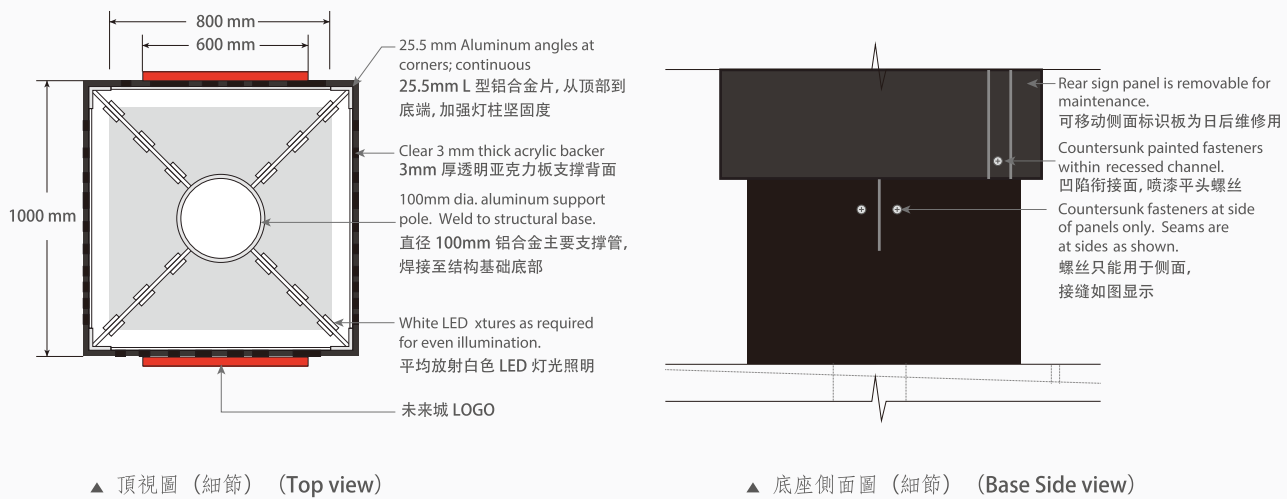
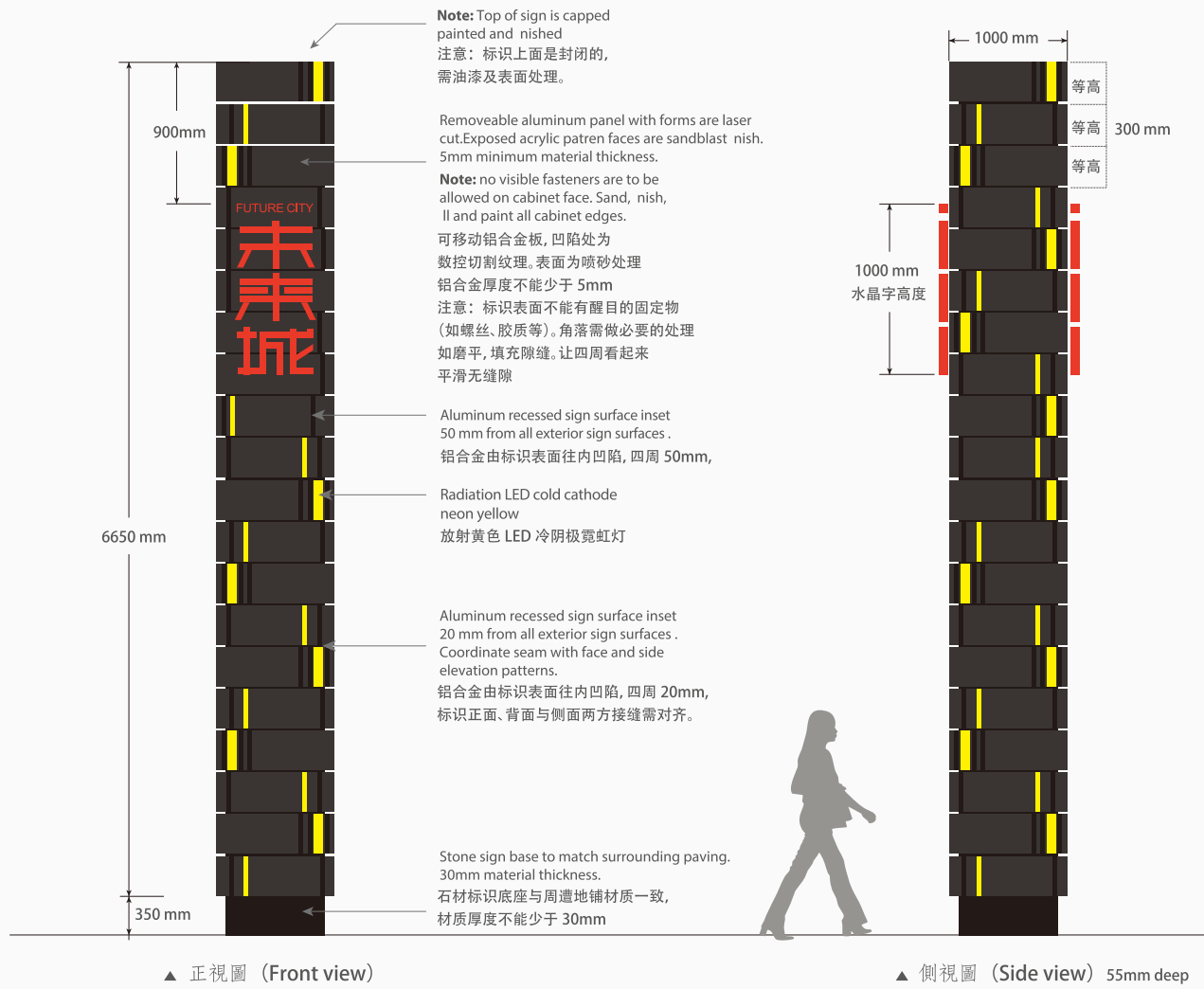

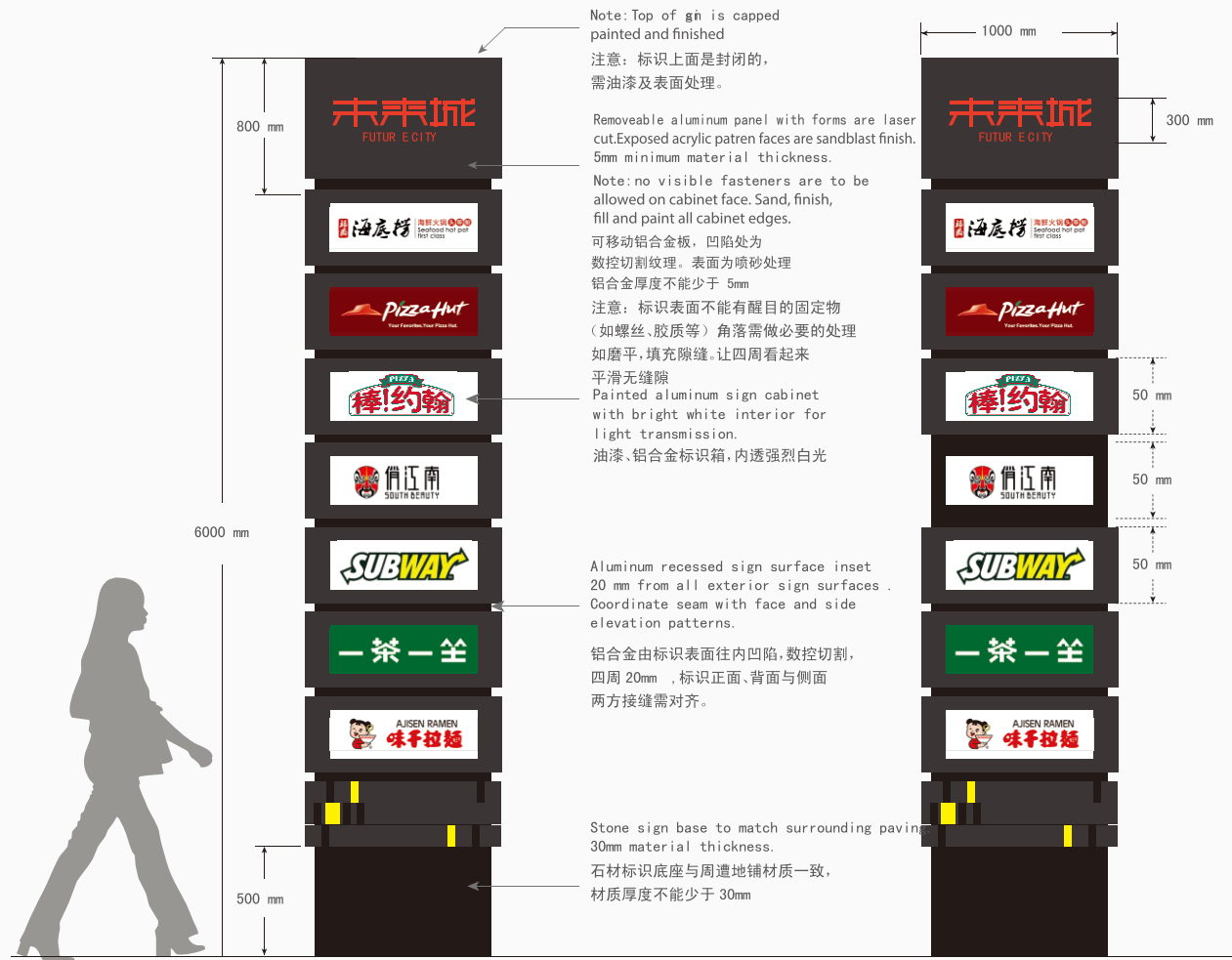

▲ 正视图 (Front view)

▲ 侧视图 (Side view) 55mm deep

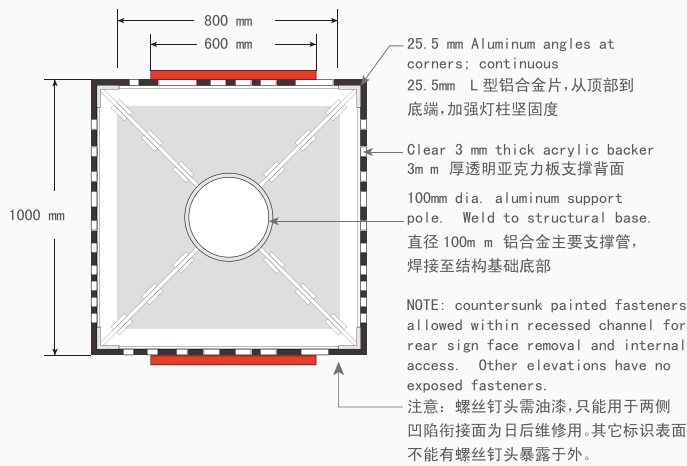

▲ 顶视图 (细节) (Top view)

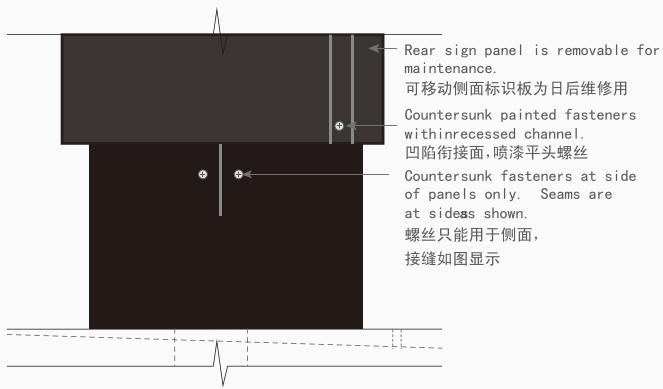

▲ 底座侧面图 (细节) (Base Side view)

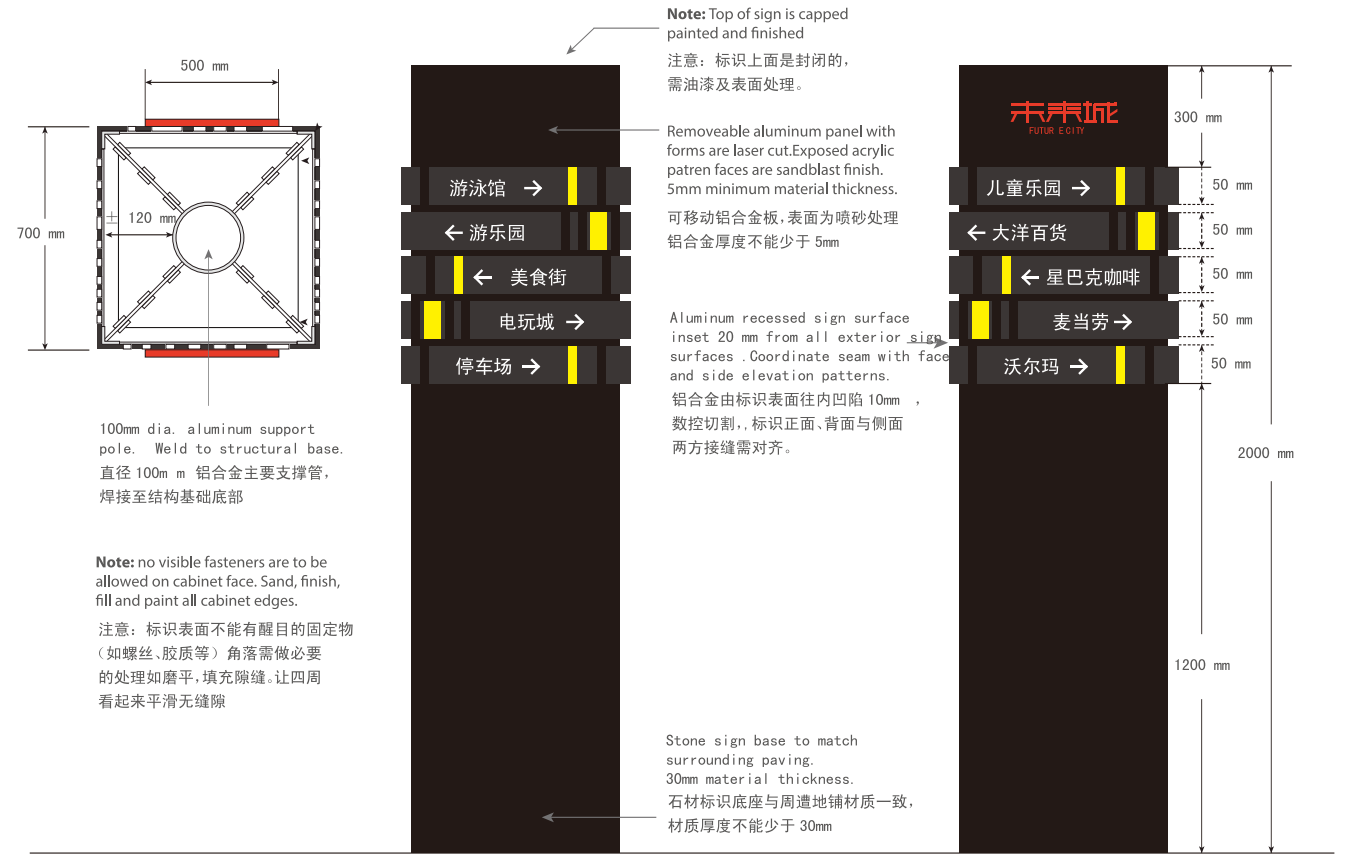

▲ 正视图 (Front view)

▲ 侧视图 (Side view)

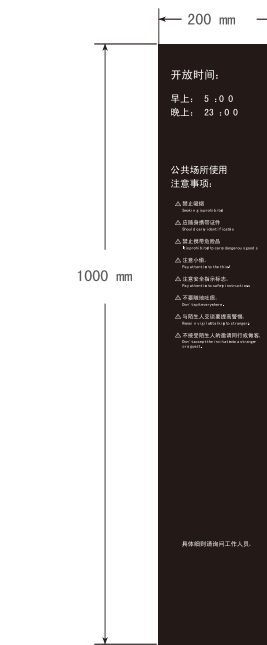

▲ 顶视图 (细节) (Top view)

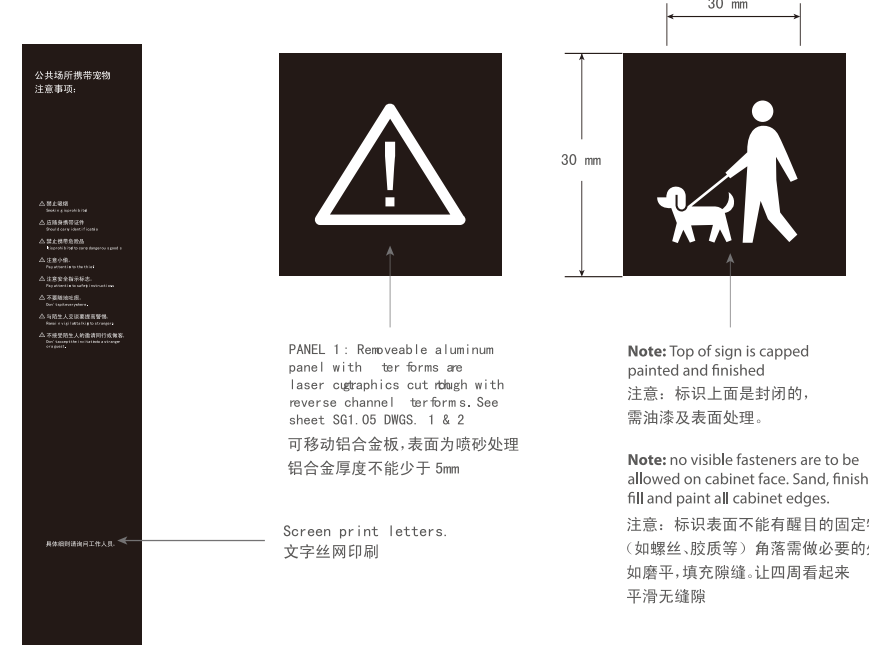

▲ 底座侧面图 (细节) (Base Side view)



1923 度假酒店，位于尖沙嘴闹市。酒店的 723 间客房包括嘉宾轩、行政套房及 4 间总统套房。住客除可使用 24 小时客房送餐服务外，酒店内 4 间餐厅提供粤菜、欧陆菜及国际美食以供选择。分别为

希戈餐厅、香港凯悦轩、弥敦餐厅及酒廊和咖啡厅。供应多个国家的特色美食，加上环境舒适宁静，绝对是与三五知己把酒言欢、共进美食的好去处。

酒店设有多个会议厅可为宾客提供完善的设施及不同形式的场地，是举行大型会议或小型聚会的理想地点。位于酒店大堂的商务中心为入住的商务旅客提供完善的商务及专责秘书服务及设施。

1923 Resort Hotel located in Tsim Sha Tsui downtown and owns 727 rooms including Regency Club, executive suites and four presidential suites. Guests can enjoy 24-hour room service here, the hotel also offers four restaurants to guests, which are named Hill Restaurant, Regency Club restaurant, Nathan restaurant and coffee house. Cantonese Cuisine, Continental Cuisine and other international cuisine can be chosen from by guests in these four restaurants. Supplying many countries cuisine, plus a comfortable environment, so here is a good place for food, drink and a laugh with two or three friends. hotel also supply meeting rooms and venues for guests, it is an ideal place to hold meetings or small gatherings. The business center is located in the hotel lobby and provide travelers with full business services including dedicated secretarial services and facilities.

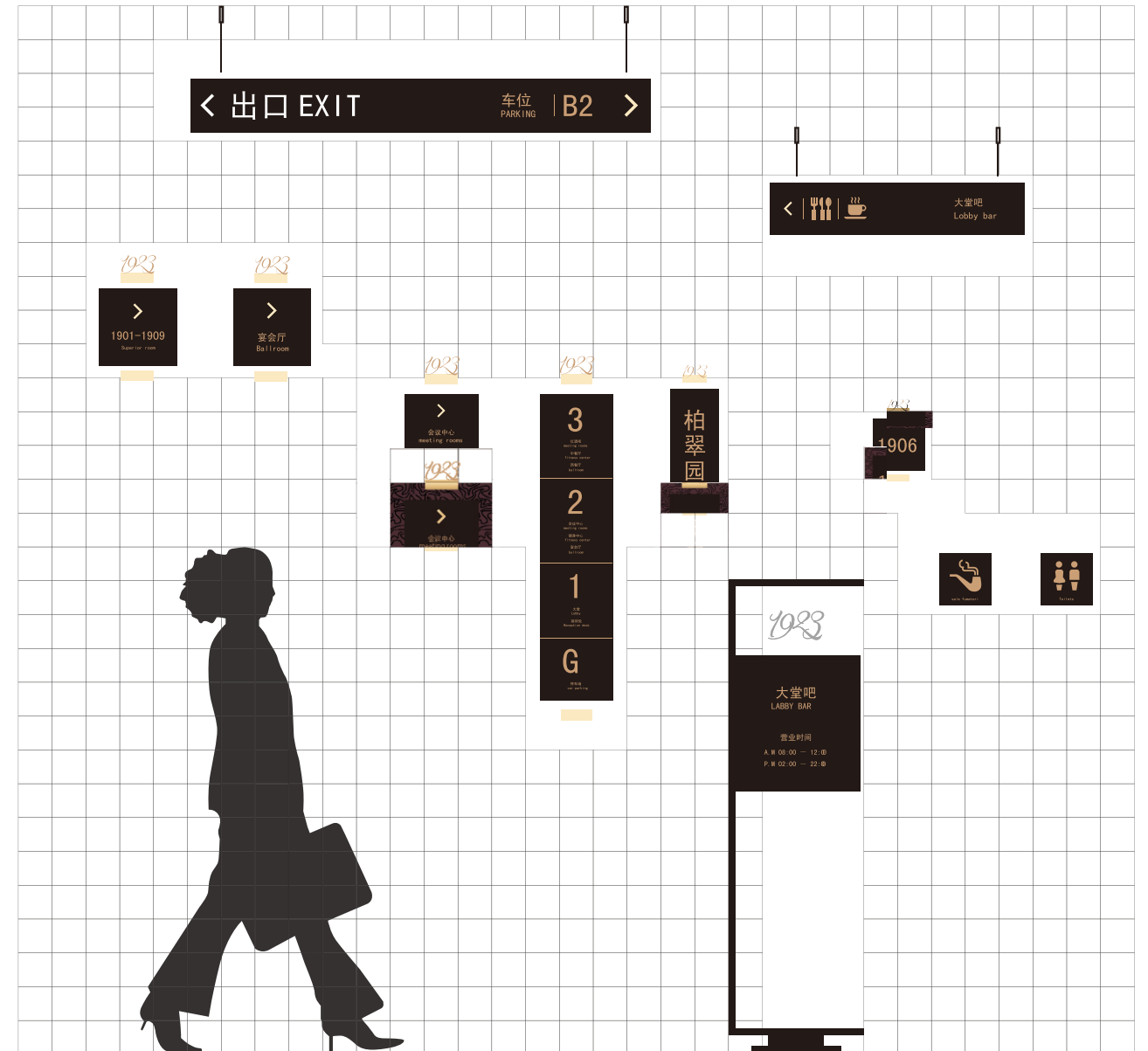

客房指示

Room
Instructions

区域方向指示

Region
Directions

楼层分布

Floor
distribution

吊牌

Tags

客房门牌

Guest room
door

Typefaces

ABCDEFGHIJKLMNOPQRSTUVWXYZ
abcdefghijklmnopqrstuvwxyz
1234567890!?!&

Flecha



Icons



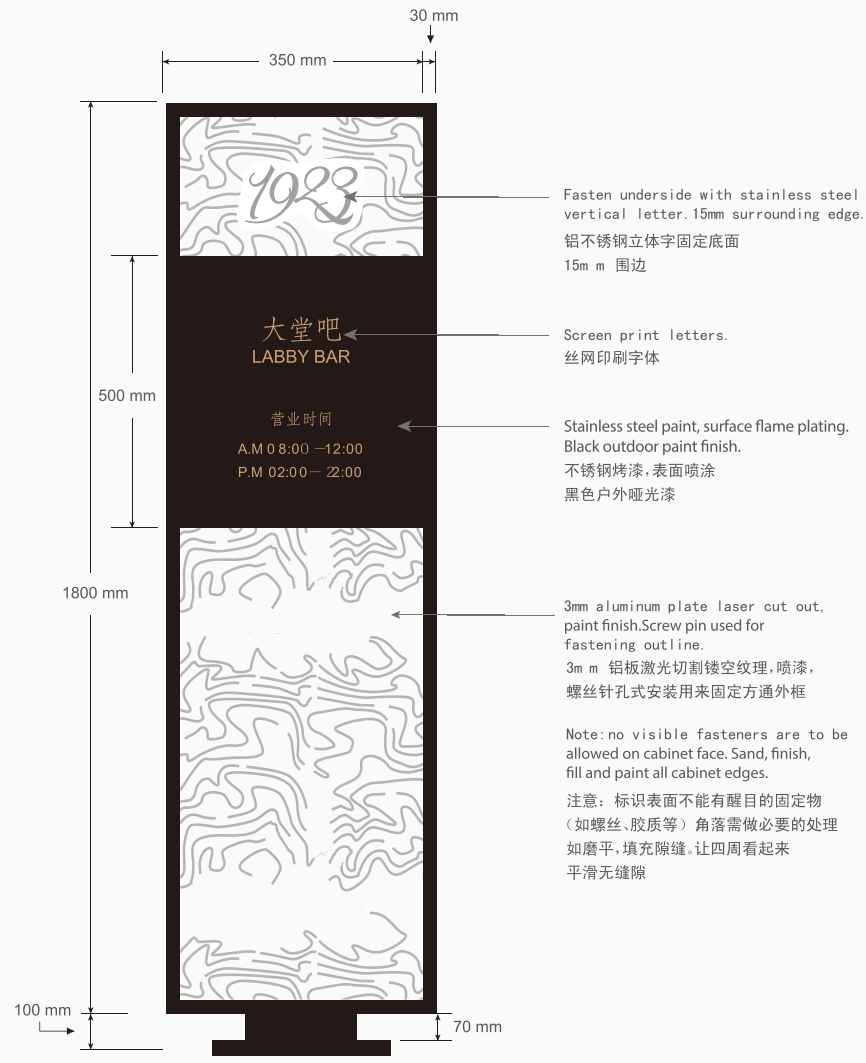

▲ 正视图 (Front view)

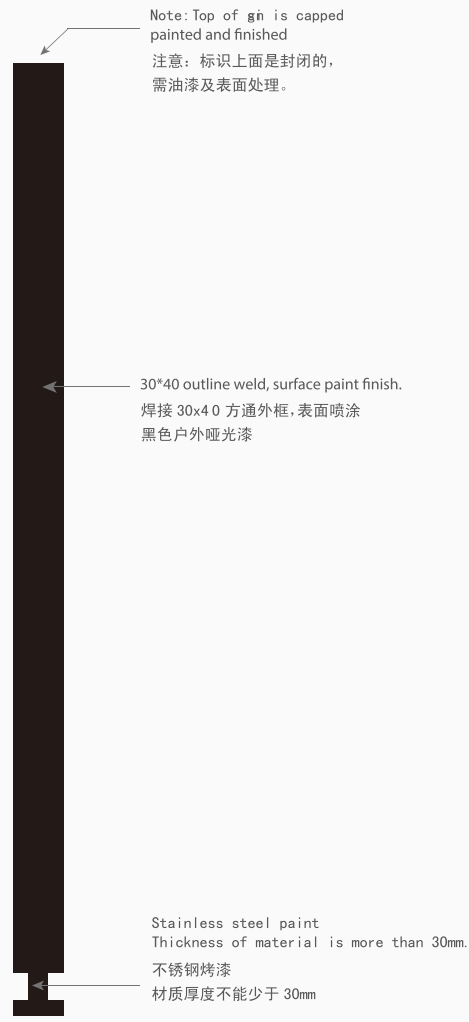

▲ 侧视图 (Side view)

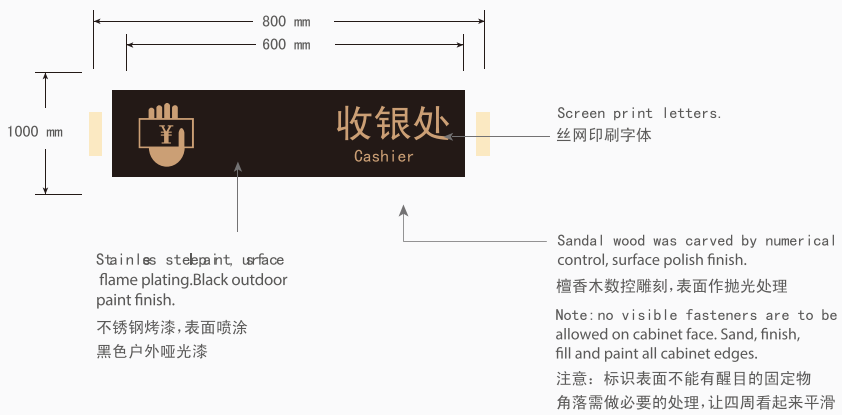

▲ 正视图 (Front view)

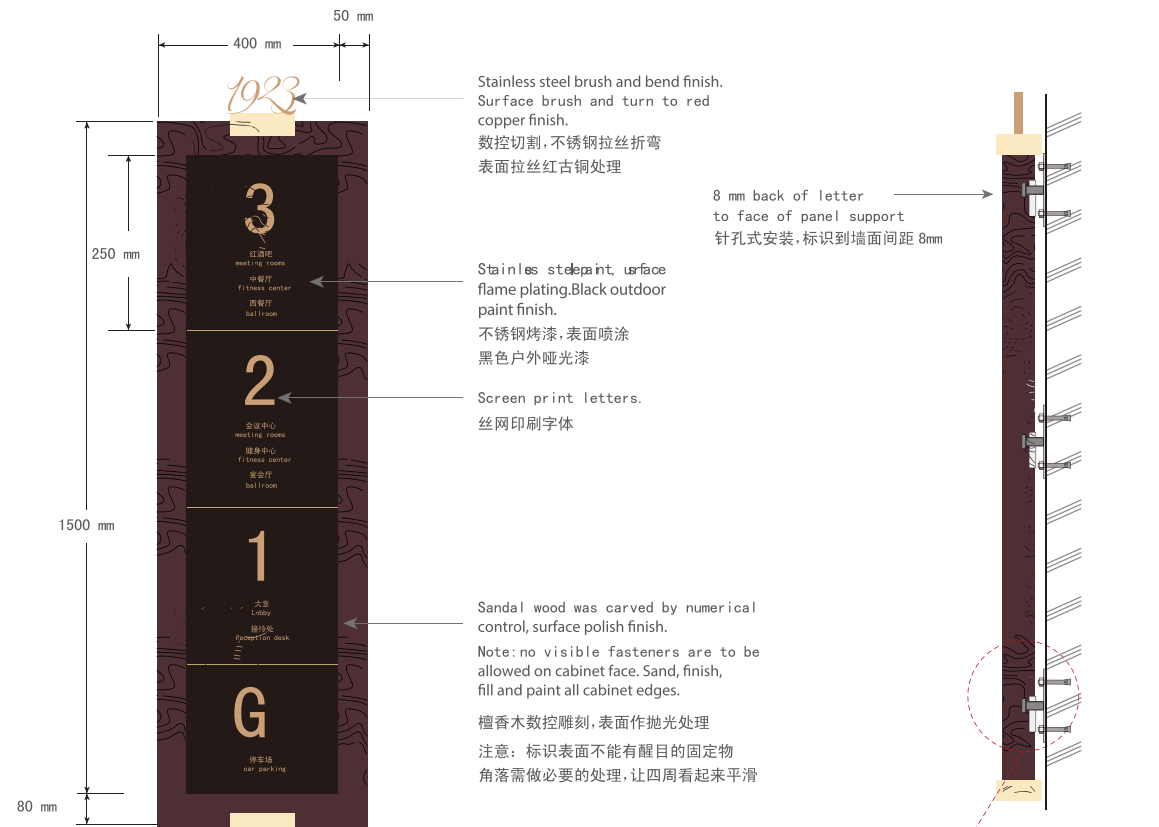
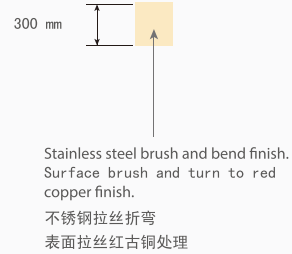

▲ 正视图 (Front view)

▲ 侧视图 (Side view)

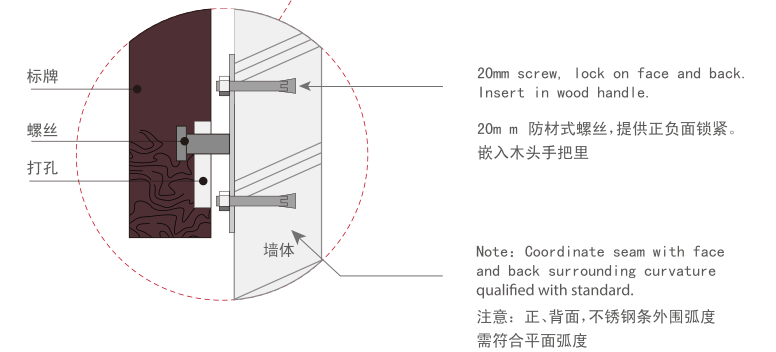
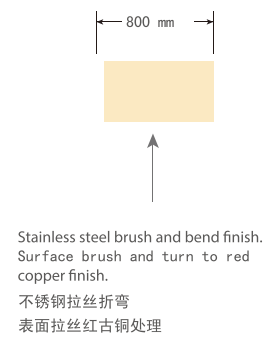

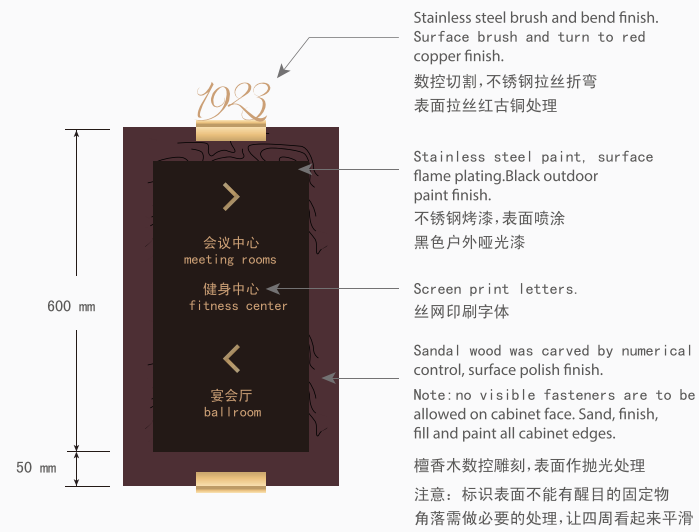

▲ 正视图 (Front view)



▲ 正视图 (Front view)

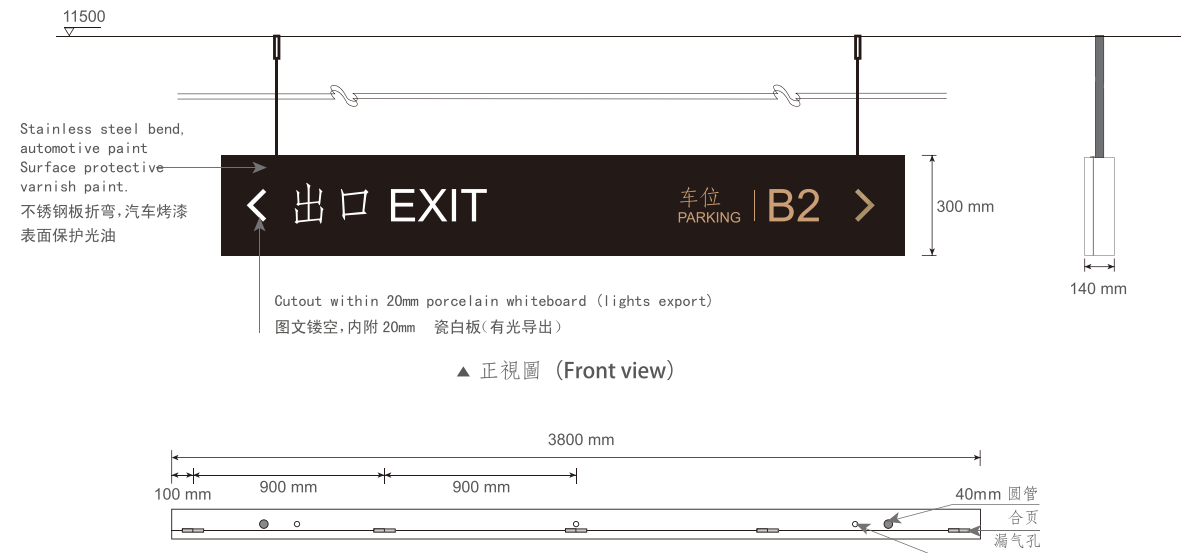
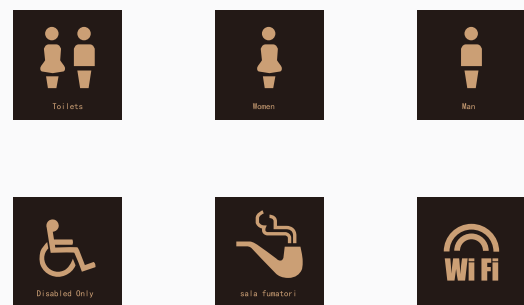

▲ 正视图 (Front view)

▲ 顶视图 (Top view)

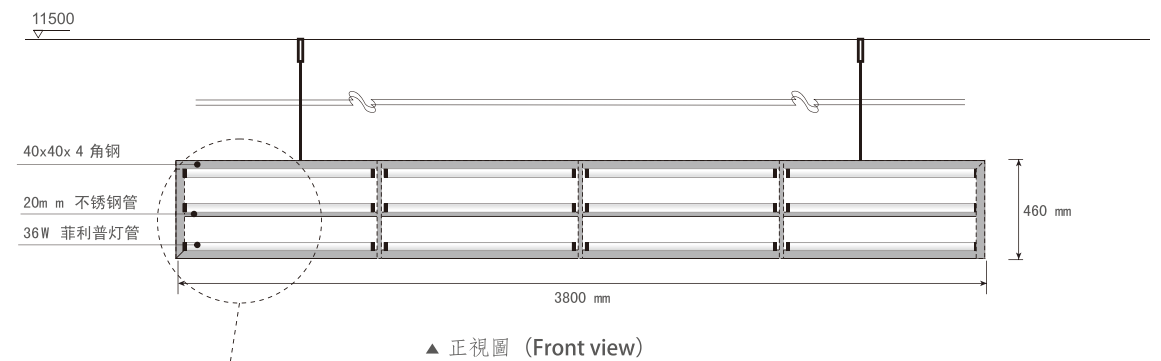

▲ 正视图 (Front view)

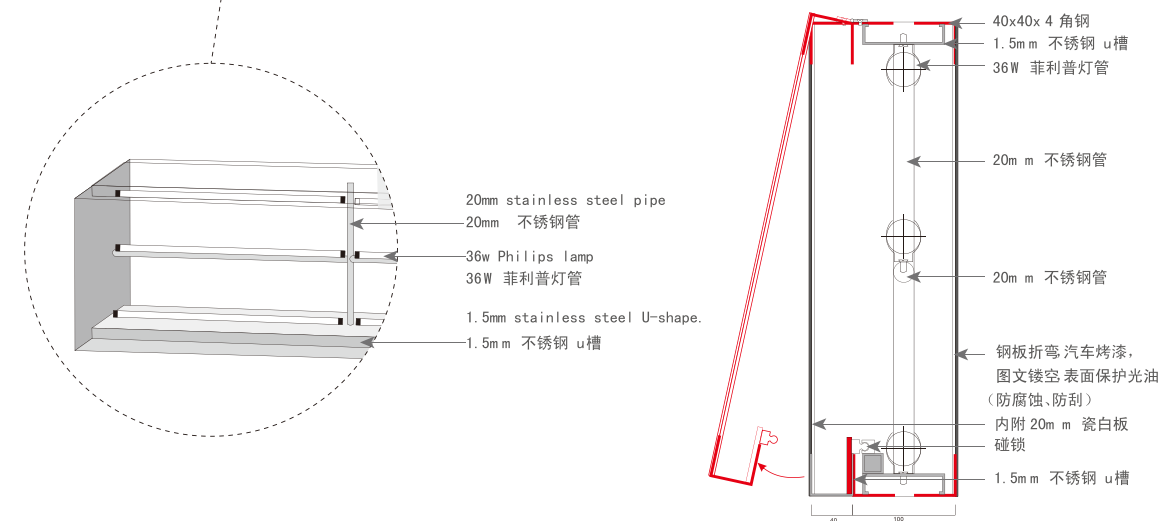

▲ 细节图 (Detail view)

▲ 剖面图 (Cross-section)

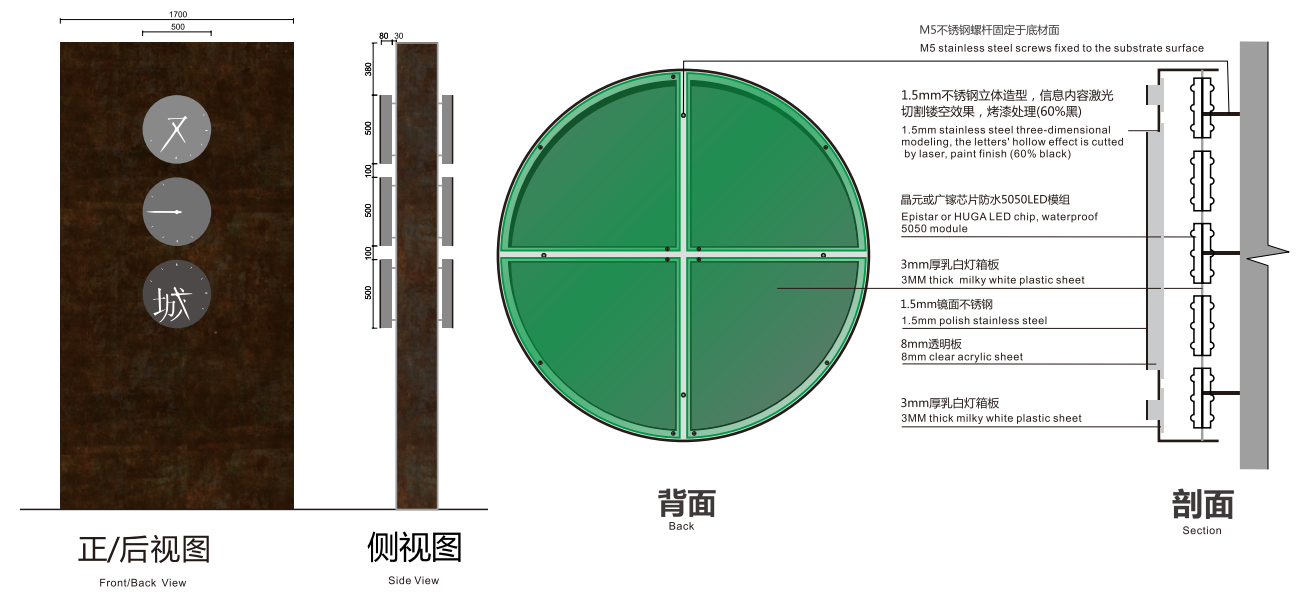
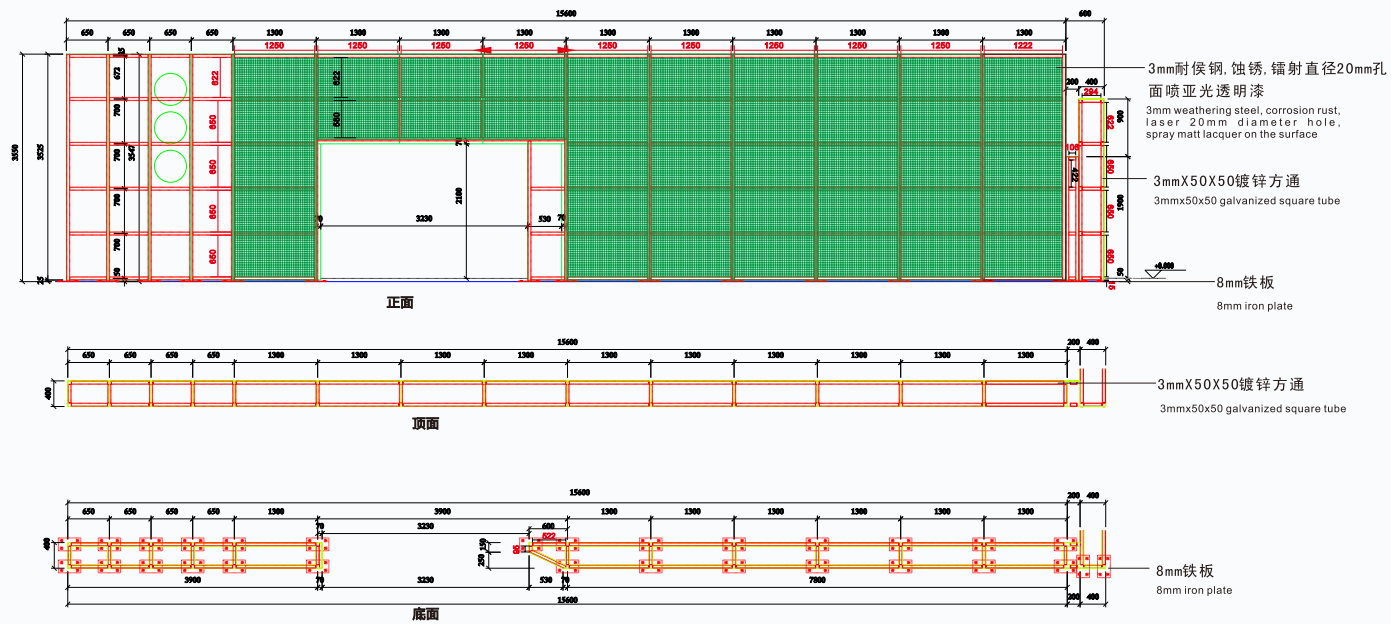
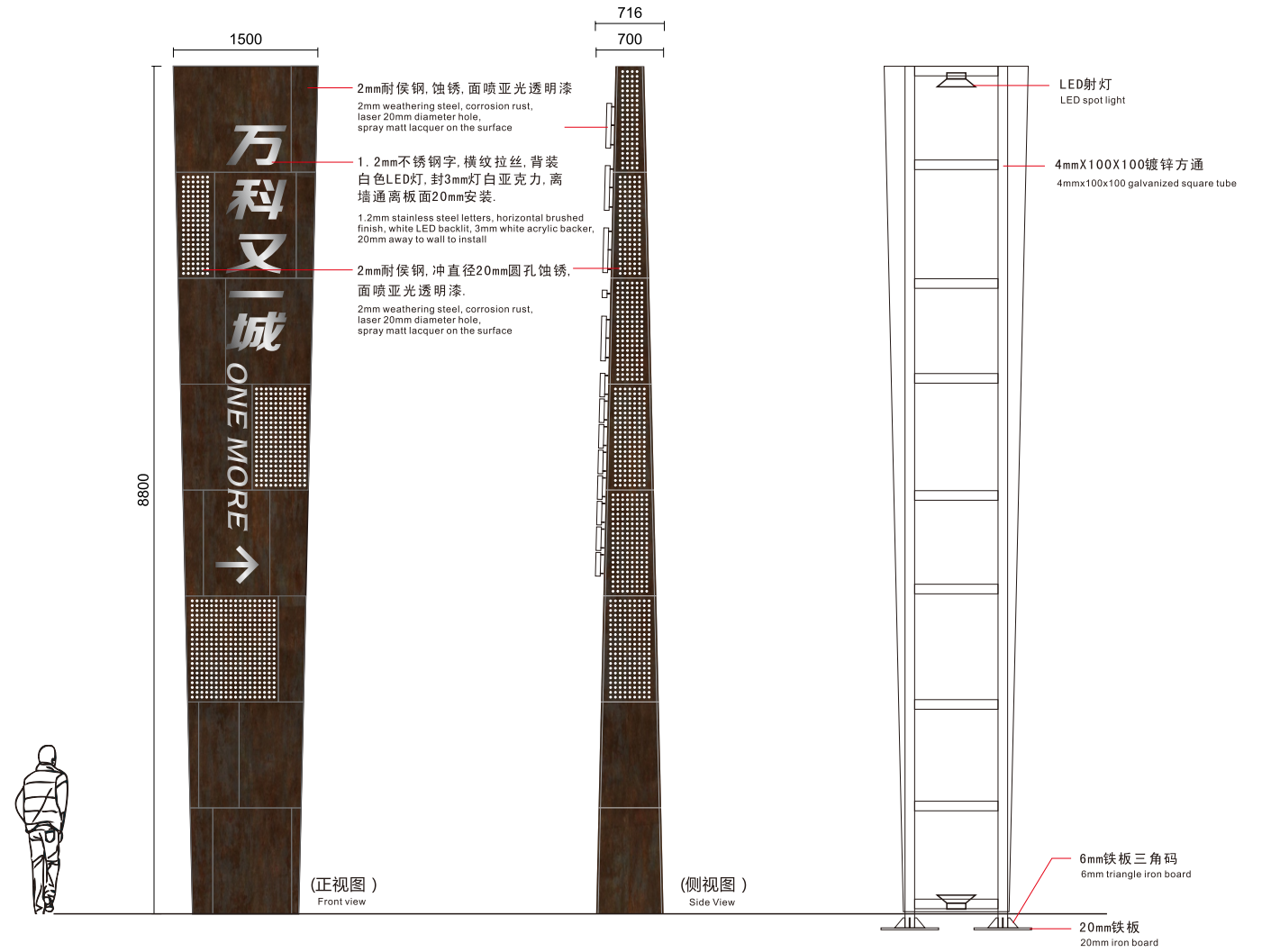

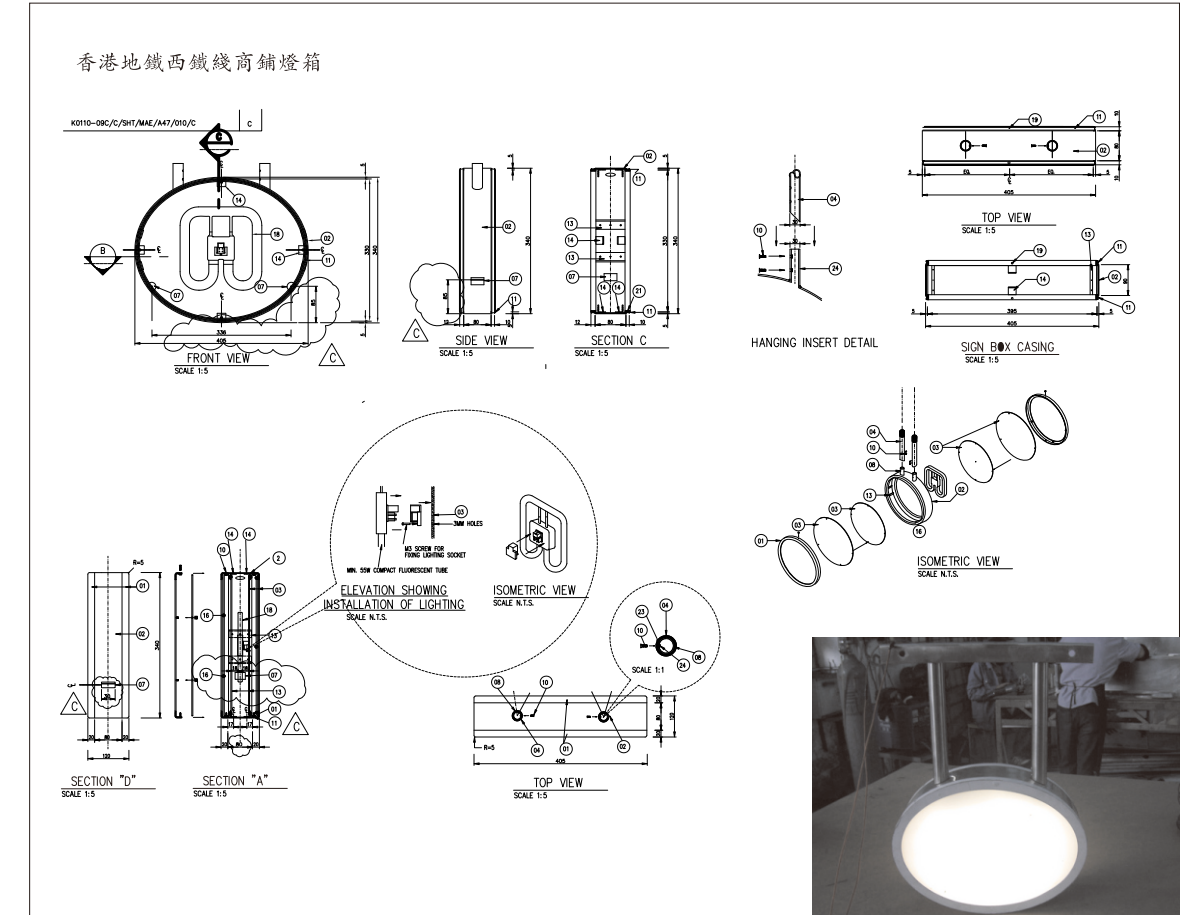
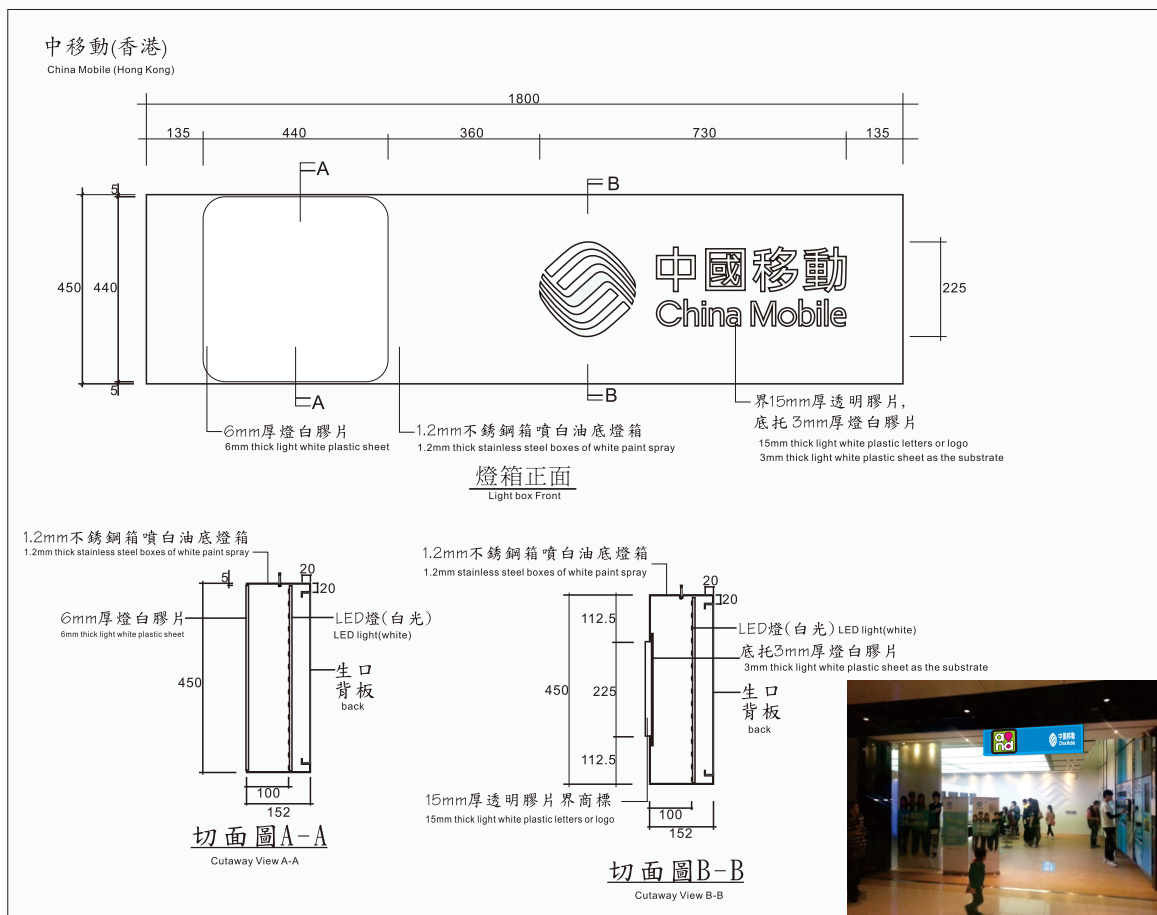
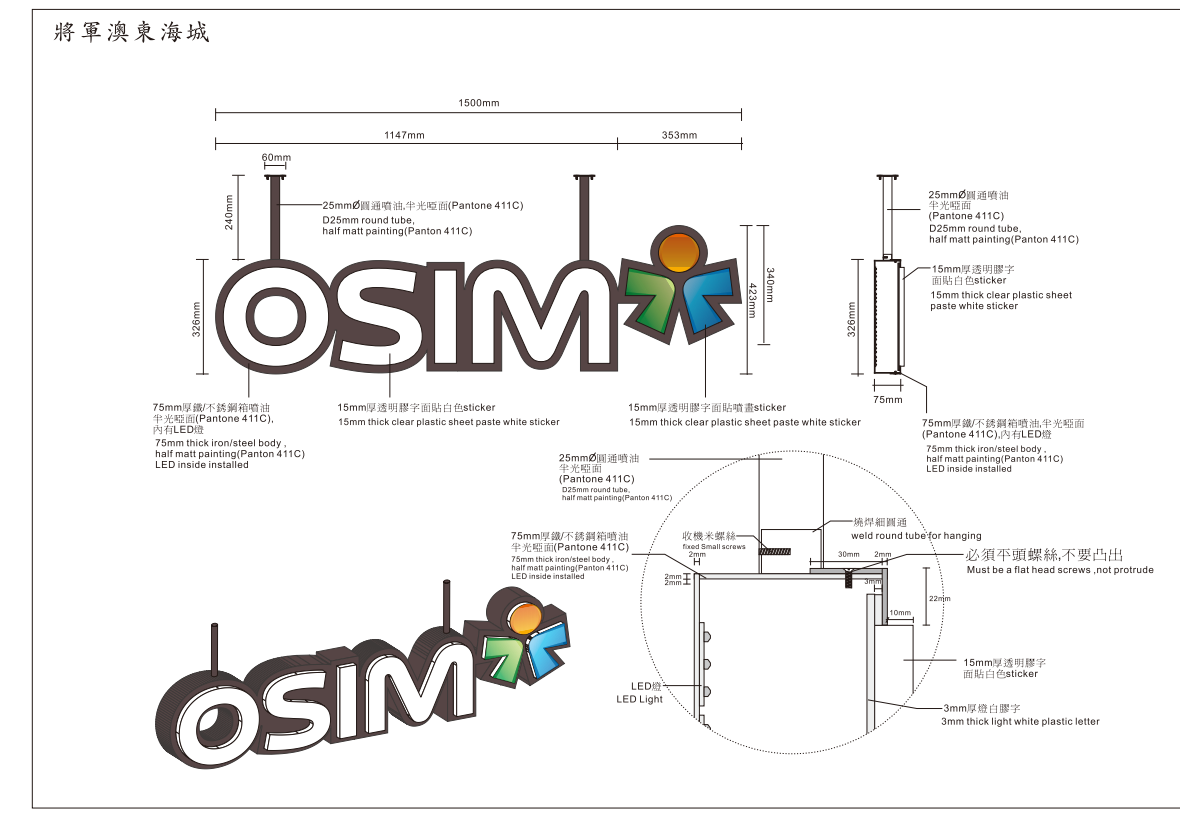
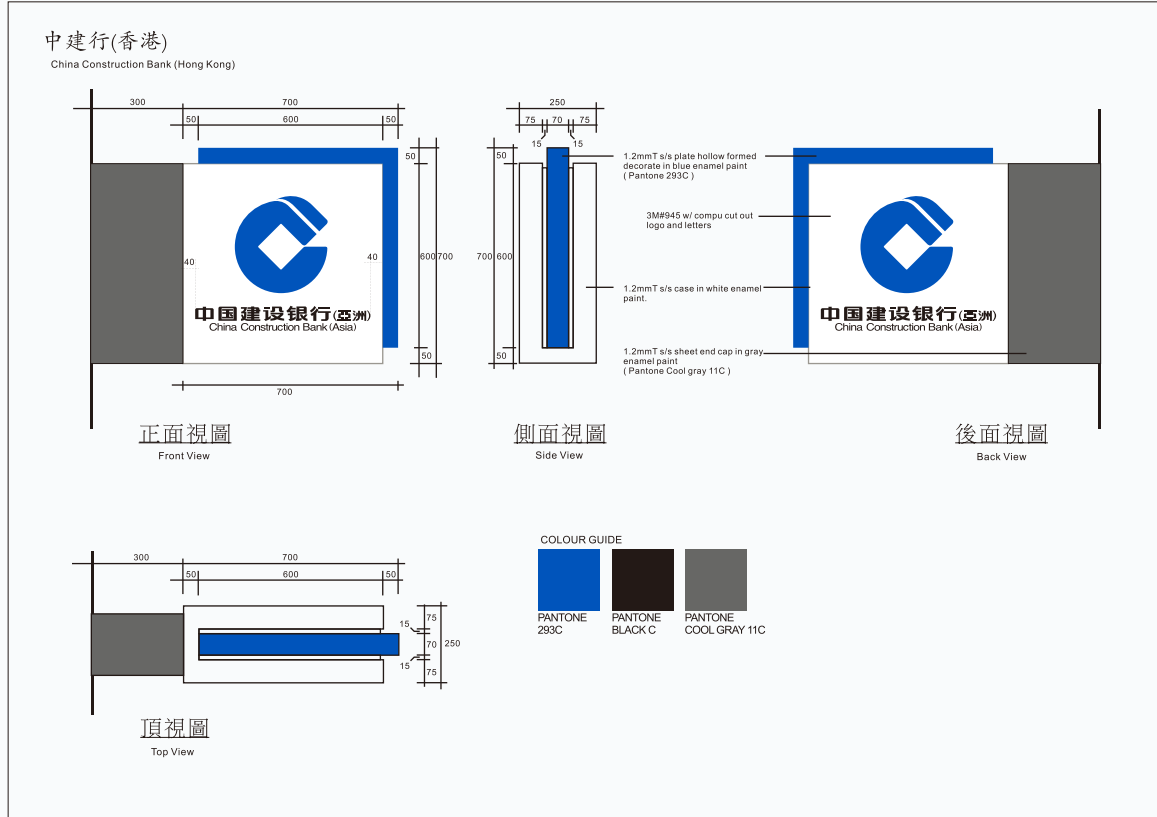



- ▲ Company Location
公司所在地
- Business spread
业务分布